

# WHAT DOES THE BOOK OF MORMON TEACH?

Class 13



What Does The Book of Mormon Teach.  
A Clear Explanation of Salvation.  
(And Learning from .....Air Traffic Control??)



# What Does the Book of Mormon Teach

Class #13

April 25, 2021

Colbern Rd. Congregation

Scan Here to Find These Notes Online!



# Scriptures Explaining Resurrection.

These ALL TELL THE SAME STORY:

THAT GOD HAS ALL POWER TO SAVE ALL WHO  
WILL COME TO HIM, TO RETURN TO HIS PRESENCE.

- [Mosiah 8](#)
- [Mosiah 8 DC 76 Compare](#)
- [The Final State.](#)
- [Rev 20-Book ends. Establishes 1<sup>st</sup> and Last resurrection, \(2<sup>nd</sup> resurrection, Second death\)](#)
- [John 5:29—Resurrection of just/unjust](#)
- [Willful Rebellion/Loosing Bands](#)
- [DC 85:4-6](#)
- [DC 85:25-34](#)
- [DC 85 Compare](#)
- [DC 28:6-7](#)
- [Timeline](#)
- [Thieves](#)
- [Prison House](#) (DC 76:7)
- [1 Corinthians 15](#)
- [DC 76](#)
- [Compare Book of Mormon, Bible, DC](#)
- [Not a handwidth but an eternal gulf.](#)
- [Book of Mormon Teaches Salvation](#)
- [Judged by Works](#)
- [Whose Merits?](#)
- [Mercy and Justice BOM vs Mormonism](#)
- [Steps to LDS Salvation?](#)
- [How Could I Be Happy???](#)
- [What the Book of Mormon Teaches Salvation IS...Guilty or Guilt Free.](#)
- [Alma 19:63-71](#)
- [Kingdom 'of God or Heaven?'](#)
- [Common Language](#)
- [ATC](#)

# (FUTURE Class) Quotes

- Joseph Smith
  - Celestial or Nothing
- Hyrum Smith
  - Stop Preaching Untruths
- Many LDS Leaders
  - Infinite Salvation
  - Celestial Marriage equated
  - With 'achieving' Celestial Reward
- WW Phelps
  - Parable of Servants fulfilled
- Parley Pratt
- Brigham Young—this is the Millennium

# Is this Familiar to Anyone? Can you Read it?

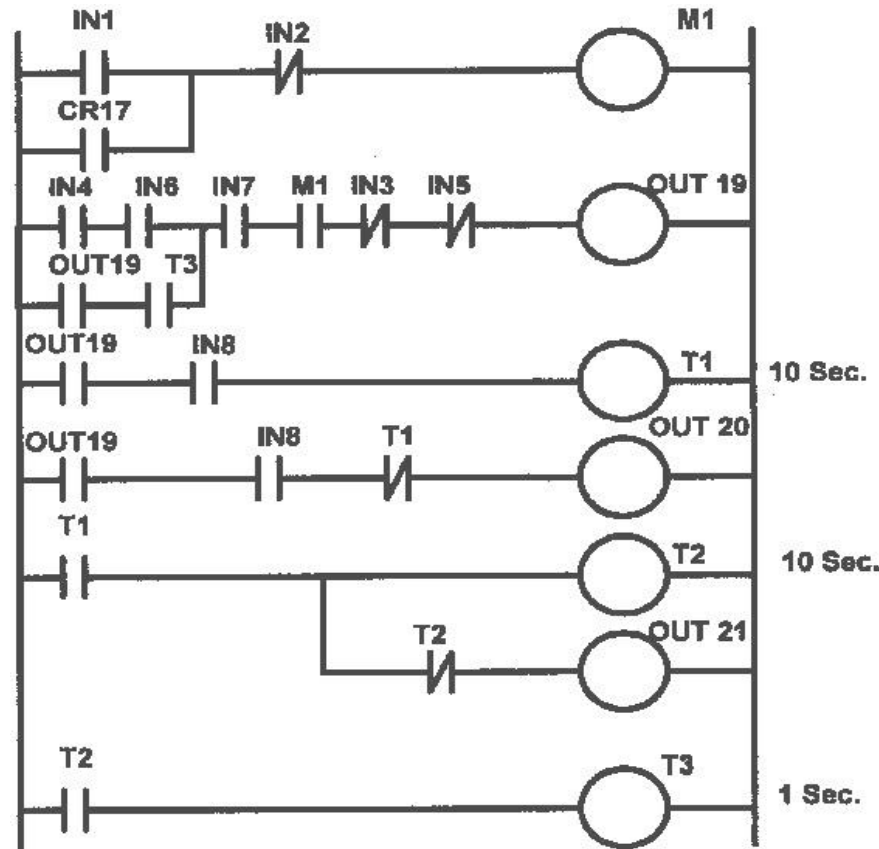



Is this Familiar to Anyone?

# Is this Familiar to Anyone?





# Chemical Plant, South Korea

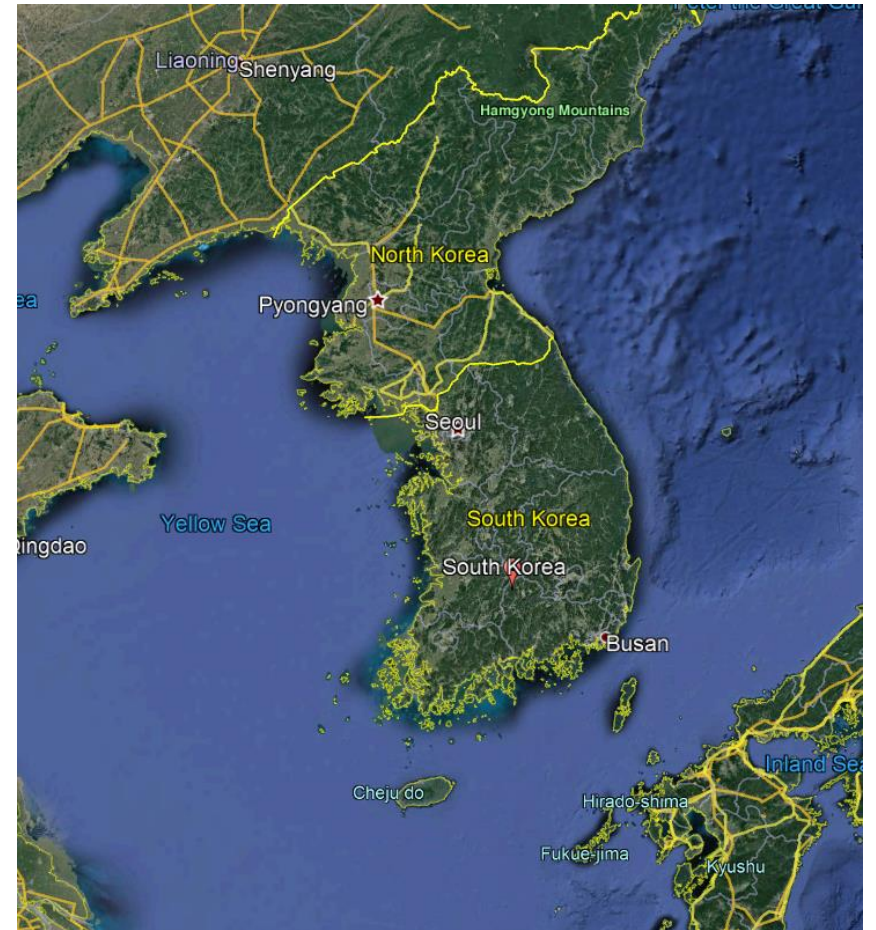

# A 'Common' Language...

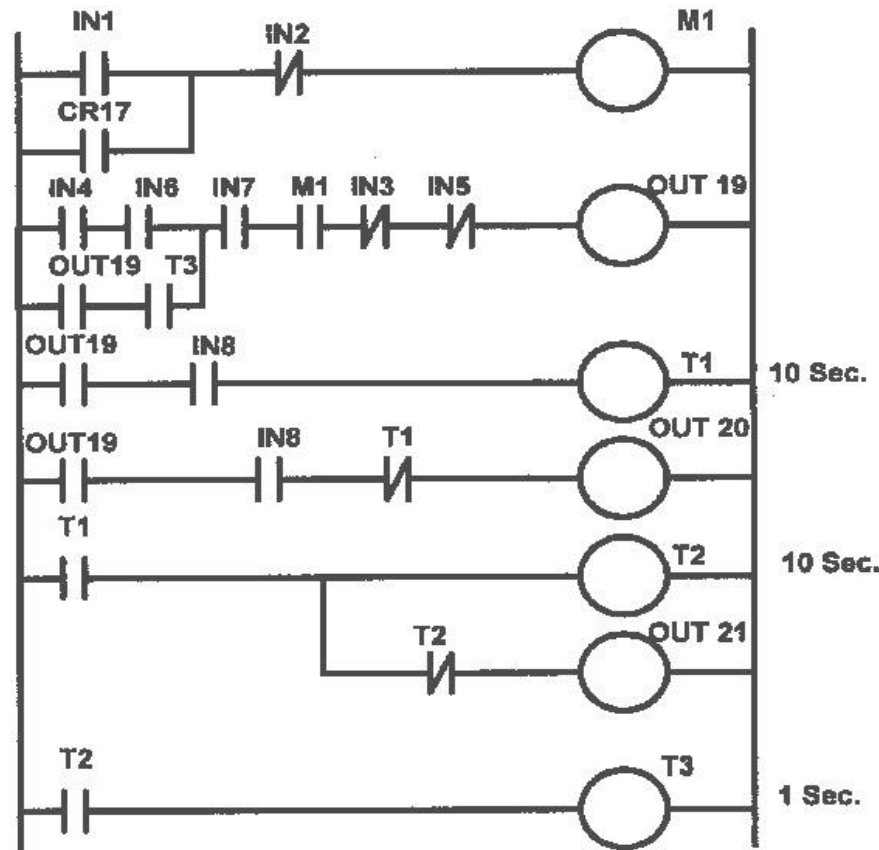

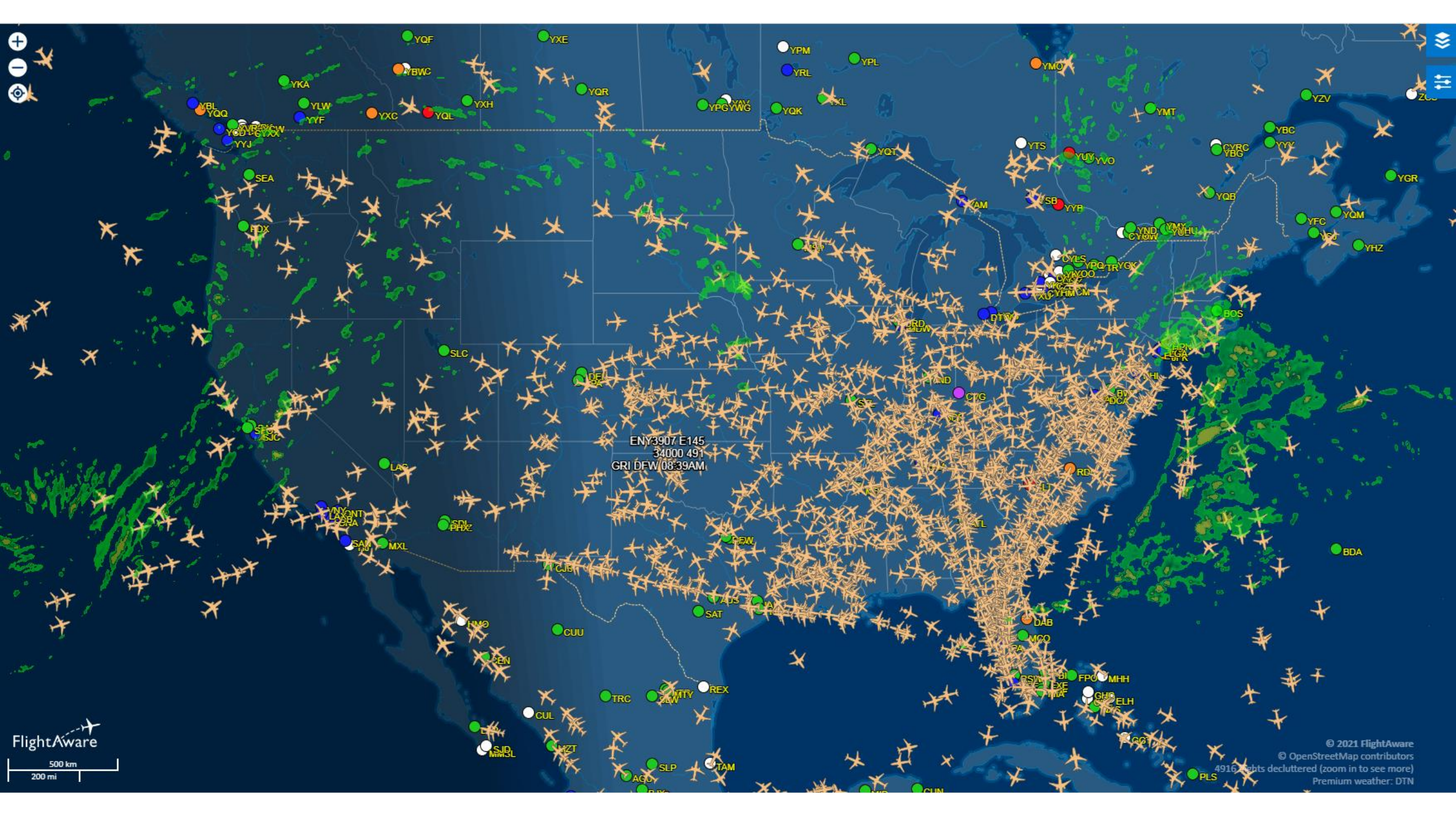

ENY3907 E145  
34000 491  
GRI DFW 08:39AM

FlightAware  
500 km  
200 mi

© 2021 FlightAware  
© OpenStreetMap contributors  
4916 flights decluttered (zoom in to see more)  
Premium weather: DTN

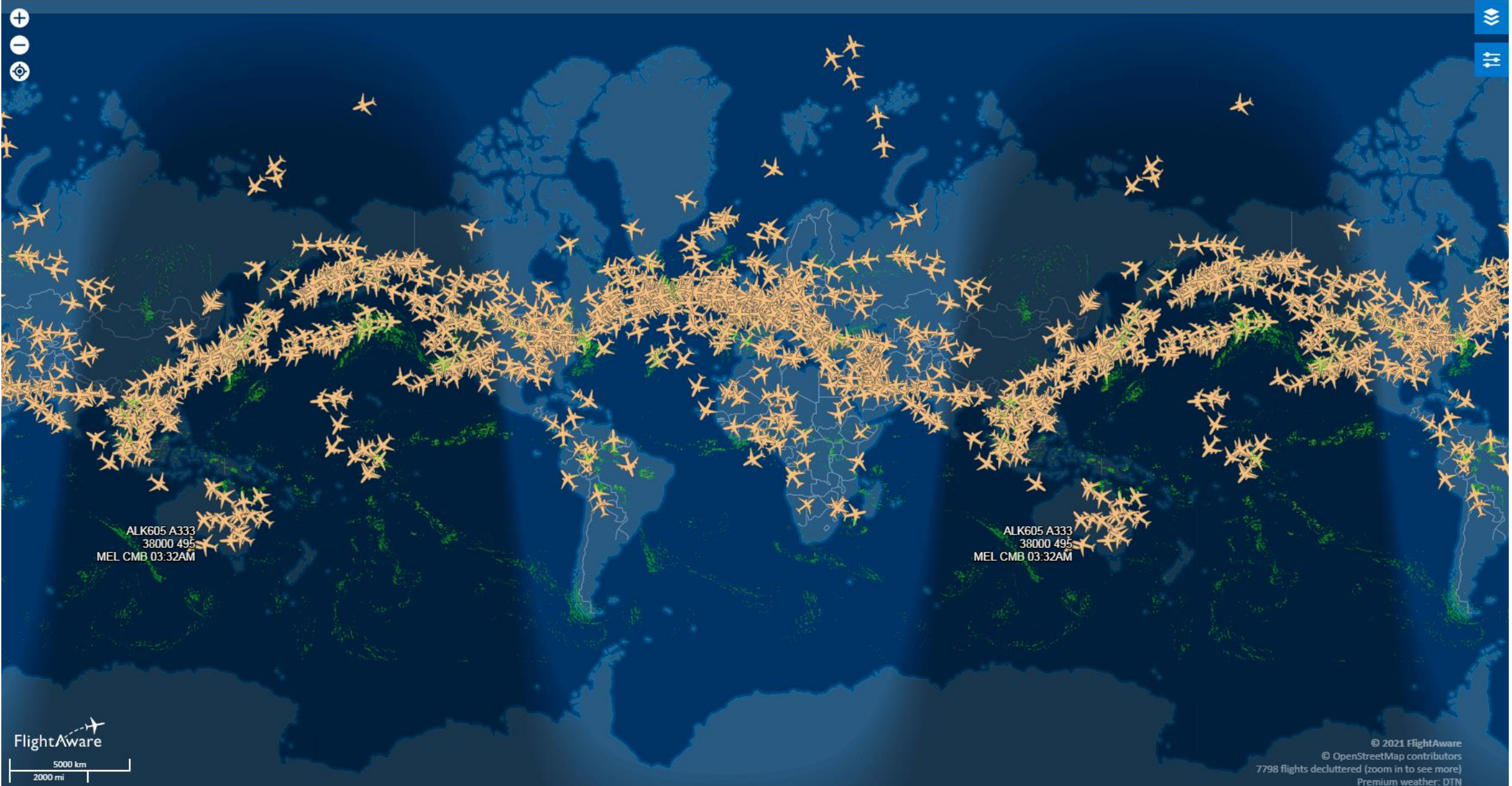

ALK605 A333  
38000 495  
MEL CMB 03:32AM

ALK605 A333  
38000 495  
MEL CMB 03:32AM

FlightAware

5000 km  
2000 mi

© 2021 FlightAware  
© OpenStreetMap contributors  
7798 flights decluttered (zoom in to see more)  
Premium weather: DTN

# Air Traffic Control—How Does it Work?



All Pilots/Controllers  
World Wide Speak  
English.

--only about 150  
words in English

Words are Distinct,  
can not be confused.

# Air Traffic Control—How Does it Work?



- ‘Descend/ Climb’
- CAN NOT BE MISHEARD or MISUNDERSTOOD
- ‘Cleared for takeoff’  
ONLY means ONE THING
- ‘Turn Left’
- MayDay

# Air Traffic Control—How Does it Work?

<b>A</b> = Alpha	<b>H</b> = Hotel	<b>O</b> = Oscar	<b>V</b> = Victor
<b>B</b> = Bravo	<b>I</b> = India	<b>P</b> = Papa	<b>W</b> = Whiskey
<b>C</b> = Charlie	<b>J</b> = Juliet	<b>Q</b> = Quebec	<b>X</b> = X-Ray
<b>D</b> = Delta	<b>K</b> = Kilo	<b>R</b> = Romeo	<b>Y</b> = Yankee
<b>E</b> = Echo	<b>L</b> = Lima	<b>S</b> = Sierra	<b>Z</b> = Zulu
<b>F</b> = Foxtrot	<b>M</b> = Mike	<b>T</b> = Tango	
<b>G</b> = Golf	<b>N</b> = November	<b>U</b> = Uniform	

## Examples

- B, D is Bravo, Delta
- M,N is Mike November
- 9 is 'Niner' to not be confused with '5' (which becomes 'fife')

# Air Traffic Control—How Does it Work?



**Controllers are THE AUTHORITY.**

**They issue the commands but ALSO sit as JUDGE AND JURY if commands are not followed.**



# Book of Mormon uses words THAT CAN NOT BE CONFUSED.

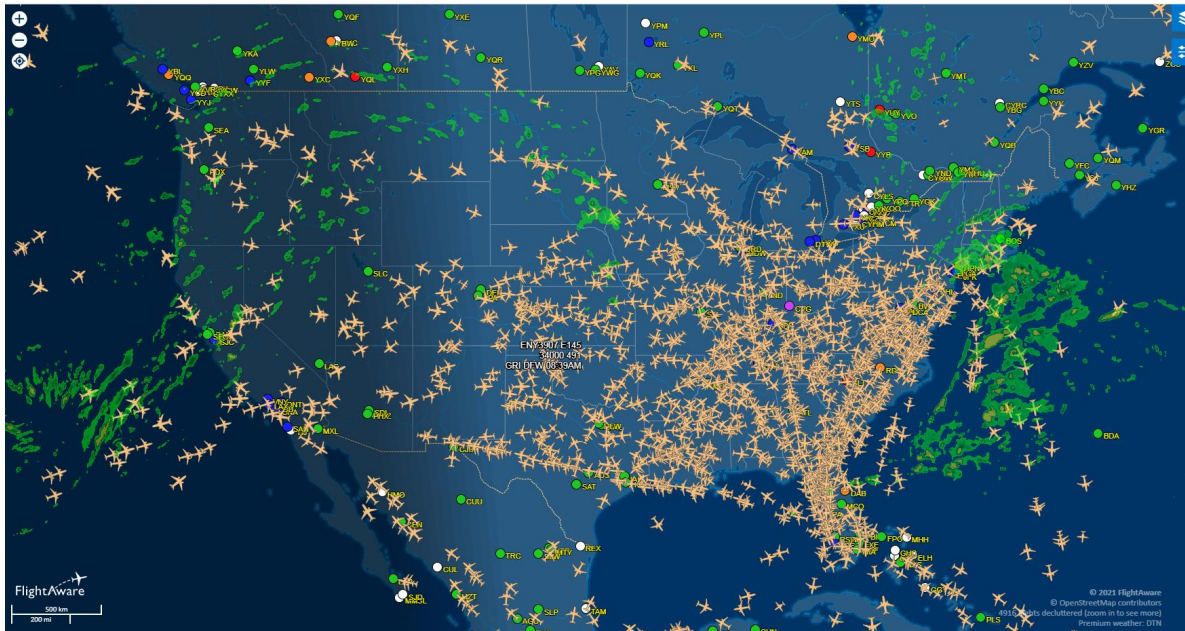

[2 Nephi 11:37](#) And now my brethren, I have spoken plain that ye cannot err;

[Alma 3:72](#) For behold, I have spoken unto you plain that ye cannot err, or have spoken according to the commandments of God,

[Alma 10:21](#) and they are made known unto us in plain terms that we may understand, that we cannot err, ....

# Mosiah 8 Describes...

## Who is Resurrected to Life (Return to God)

- Those who obeyed
- Those who died without the Law
- Little Children

## Who is Resurrected to Death...(Separation from God)

- Those who **willfully Rebelled**—they knew the commandments but would not keep them.

# Mosiah 8—Abinadi Explains Resurrection

[Mosiah 8:14](#) Yea, and have they not said also that He should bring to pass the **resurrection** of the dead and that He, Himself, should be oppressed and afflicted?

[Mosiah 8:54](#) "But behold, the bands of death shall be broken; And the Son reigneth and hath power over the dead; Therefore, He bringeth to pass the **resurrection** of the dead.

[Mosiah 8:55](#) "And there cometh a **resurrection**, even a first **resurrection**; Yea, even a **resurrection** of those that have been, and which are, and which shall be, Even until the **resurrection** of Christ, for so shall He be called.

# Mosiah 8—Abinadi Explains Resurrection

[Mosiah 8:56](#) "And now, the **resurrection** of all the prophets and all those that have believed in their words, or all those that have kept the commandments of God, These shall come forth in the first **resurrection**; Therefore, they are the first **resurrection**;

[Mosiah 8:58](#) "And there are those who have part in the first **resurrection**; And these are they that have died before Christ came, in their ignorance, not having salvation declared unto them;

[Mosiah 8:59](#) And thus the Lord bringeth about the restoration of these; And they have a part in the first **resurrection**, or hath eternal life, being redeemed by the Lord.

# Mosiah 8—Abinadi Explains Resurrection

[Mosiah 8:62](#) Yea, even all those that have perished in their sins ever since the world began, that have willfully rebelled against God, that have known the commandments of God and would not keep them; These are they that have no part in the first **resurrection**.

[Mosiah 8:80](#) And if Christ had not risen from the dead, or have broken the bands of death that the grave should have no victory and that death should have no sting, there could have been no **resurrection**.

# Mosiah 8—Abinadi Explains Resurrection

[Mosiah 8:81](#) "But there is a **resurrection**;  
Therefore, the grave hath no victory, And  
the sting of death is swallowed up in Christ.

## [Mosiah 8:84](#)

If they be good, to the **resurrection** of  
endless life and happiness;

And if they be evil, to the **resurrection** of  
endless damnation,

# Mosiah 8 (Abinadi's Message) with DC 76—teach the same message.

MOSIAH 8	DC 76
<b>ABINADI'S DESCRIPTION:</b> "All who have kept commandments"	<b>DESCRIPTION:</b> JS calls them 'Celestial' because of the amount of Light and Truth they have of God.
40 And who shall be his seed?	76:5a ... concerning them <b>who come forth in the resurrection of the just:</b>
41 Behold, I say unto you, <b>that whosoever has heard the words of the prophets</b>	76:5b ... who received the testimony of Jesus, and believed on his name, and were baptized ...that by <b>keeping the commandments</b> , they might be washed and cleansed from all their sins,
42 all those who <b>have hearkened unto their words, and believed that the Lord would redeem his people, and have looked forward to that day for a remission of their sins;</b>	76:5c and receive the Holy Spirit 76:5g .. who have received of his fullness, and of his glory, 76:5k these <b>are they whom he shall bring with him, when he shall come in the clouds of heaven, to reign on the earth over his people;</b>
43 I say unto you, that <b>these are his seed, or they are heirs of the kingdom of God:</b>	76:5l these are they who <b>shall have part in the first resurrection;</b>
55 And there cometh a resurrection, even a first resurrection...	76:5m these are they <b>who shall come forth in the resurrection of the just;</b>
56 And now, the resurrection of all the prophets, and all those that have believed in their words, or all those that have kept the commandments of God, <b>shall come forth in the first resurrection; therefore, they are the first resurrection.</b>	76:5n these are they who are come unto <b>Mount Zion</b> 76:5q these are they who are just men made perfect through Jesus 76:5r <b>these are they whose bodies are celestial</b>
57 They are raised to dwell with God who has redeemed them: thus they have eternal life through Christ, who has broken the bands of death.	<a href="#">Return</a>

## MOSIAH 8

### ABINADI'S DESCRIPTION:

All who died in ignorance but were good people

**Mosiah 8: 58** And these are those who have part in the first resurrection;

and these are they that have **died before Christ came,**  
in **their ignorance, not having salvation declared unto them.**

**59** And thus the Lord bringeth about the restoration of these; and they have a part in the first resurrection, or have eternal life, being redeemed by the Lord.

**8:60** And little children also have eternal life.

### Moroni 8:25

For behold that all little children are alive in Christ,  
and also all they that are without the law;

## DC 76

**DESCRIPTION:** JS calls them 'Terrestrial' because of the amount of Light and Truth they have of God.

**76:6a** And again, we saw the terrestrial world...

**76:6c** Behold, these are they **who died without law;**

and also they who are the spirits of men kept in prison, whom the Son visited, and preached the gospel unto them, **that they might be judged according to men in the flesh,** who received not the testimony of Jesus in the flesh, but afterwards received it;

**76:6d** these are they who are honorable men of the earth, who were blinded by the craftiness of men:



## MOSIAH 8

### ABINADI'S DESCRIPTION:

**All Who Have Rebelled against God, knew to keep commandments but did not.**

**61** But behold, and fear, and tremble before God; for ye ought to tremble: for the Lord redeemeth none such that rebel against him, and die in their sins;

**62** Yea, even all those that have perished in their sins ever since the world began, that have willfully rebelled against God, that have known the commandments of God, and would not keep them; these are they that have **no part in the first resurrection.**

## DC 76

**DESCRIPTION:** Same Reurrected people Mosiah describes **but JS calls them 'Telestial'** because of the amount of Light and Truth they have of God

**76:7a** And again, we saw the glory of the telestial,

**76:7b** these are they who received not the gospel of Christ, neither the testimony of Jesus; ...

**76:7d** these are they who are **thrust down to hell;**

**76:7e** **these are they who shall not be redeemed from the Devil, until the last resurrection,** until the Lord, even Christ the Lamb, shall have finished his work;

**76:7f .... for they shall be heirs of salvation.**

## MOSIAH 8

### ABINADI'S DESCRIPTION

Those for whom it is as If No Redemption Made, overcome by the Devil

**8:77** But remember, that he that **persists in his own carnal nature**, and goes on in the ways of sin and rebellion against God, **..remaineth in his fallen state, and the devil hath all power over him.**

**78** Therefore he is as **though there was no redemption made**; being an enemy to God; and also is the devil an enemy to God

**84-87** If they be good, to the resurrection of endless life and happiness, and **if they be evil, to the resurrection of endless damnation; Being delivered up to the devil**, who has subjected them, which is damnation; Having gone according to their own carnal wills and desires; having never called upon the Lord while the arms of mercy were extended towards them; **For the arms of mercy were extended towards them, and they would not; they being warned of their iniquities, and yet they would not depart from them;**

**8:88** And they were commanded to repent, and yet they would not repent.

## DC 76

**DESCRIPTION: JS Calls these 'Perdition' overcome by Satan.**

**76:3m** And we saw a vision of the sufferings of those **with whom he made war and overcame, ..**

**76:4a** Thus saith the Lord, concerning all those who know my power, and have been made partakers thereof, and suffered themselves, through the power of the Devil, **to be overcome, and to deny the truth, and defy my power;**

**76:4b** they are they who are the sons of perdition, of whom I say it had been better for them never to have been born;

**76:4c** for they are **vessels of wrath, doomed to suffer the wrath of God, with the Devil and his angels, in eternity**, concerning whom I have said there is no forgiveness in this world nor in the world to come;

**76:4d** having denied the Holy Spirit, after having received it,

**76:4e** these are they who shall go away into the lake of fire and brimstone, with the Devil and his angels, **and the only ones on whom the second death shall have any power;** yea, verily, the only ones who shall not be redeemed in the due time of the Lord, after the sufferings of his wrath; **for all the rest shall be brought forth by the resurrection of the dead, through the triumph and the glory of the Lamb, who was slain**, who was in the bosom of the Father before the worlds were made.

## Alma 16:234

234 Therefore, the Spirit of the Lord  
hath withdrawn from you and  
hath no place in you,  
And the devil hath all power over you.

**And this is the final state of the wicked.**

# The Final State? 1 Nephi 4:61

Wherefore, the final state of the souls of men

is to  dwell in the kingdom of God,

or to be cast out

because of that justice of which I have spoken;

# Final State of Eternity

## 3 Nephi 11:32-33

32 And even unto the great and last day when all people and all kindreds and all nations and tongues shall stand before God to be judged of their works, whether they be good or whether they be evil.

33 If they be **good**, to the resurrection of **everlasting life**,  
And if they be **evil**, to the resurrection of **damnation**,  
Being on a parallel, the one on the one hand,  
and the other on the other hand –

According to the **mercy** and the **justice** and the holiness which is in Christ,  
which was before the world began.

# Revelation 20

**20:1** And I saw an angel come down out of heaven, having the key of the bottomless pit and a great chain in his hand.

**20:2** And he laid hold on the dragon, that old serpent, which is the Devil, and Satan, and bound him a thousand years,

**20:3** And cast him into the bottomless pit, and shut him up, and set a seal upon him, that he should deceive the nations no more, till the thousand years should be fulfilled; and after that he must be loosed a little season.

# Revelation 20

**20:4** And I saw thrones, and they sat upon them, and judgment was given unto them; and I saw the souls of them that were beheaded for the witness of Jesus, and for the word of God, and which had not worshiped the beast, neither his image, neither had received his mark upon their foreheads, or in their hands: and they lived and reigned with Christ a thousand years.

**20:5** But the rest of the dead lived not again until the thousand years were finished. This is the first resurrection.

# Revelation 20

**20:6 Blessed and holy are they who have part in the first resurrection; on such the second death hath no power, but they shall be priests of God and of Christ,** and shall reign with him a thousand years.

**20:7** And when the thousand years are expired, Satan shall be loosed out of his prison,

**20:8** And **shall go out to deceive the nations** which are in the four quarters of the earth, Gog and Magog, to gather them together to battle; the number of whom is as the sand of the sea.



# Revelation 20

**20:9** And they went up on the breadth of the earth, and compassed the camp of the saints about, and the beloved city; and fire came down from God out of heaven, and devoured them.

**20:10** And the devil that deceived them was cast into the lake of fire and brimstone, where the beast and the false prophet are, and shall be tormented day and night forever and ever.

# Revelation 20

**20:11** And I saw a great white throne, and him that sat on it, from whose face the earth and the heaven fled away; and there was found no place for them.

**20:12** And I saw the dead, small and great, stand before God; and the books were opened; and another book was opened, which is the book of life; and the dead were judged out of those things which were written in the books, according to their works.

# Revelation 20

**20:13** And the sea gave up the dead which were in it; and death and hell delivered up the dead which were in them; and they were judged every man according to their works.

**20:14** And death and hell were cast into the lake of fire. This is the second death.

**20:15** And whosoever was not found written in the book of life was cast into the lake of fire.

# Revelation 20 compared to these...

## Hebrews 11:35

...Women received their dead raised to life again;  
and others were tortured, not accepting deliverance;  
**that they might obtain the first resurrection;**

## Revelation 2:11

He that hath an ear, let him hear what the Spirit saith unto the churches;

**He that overcometh shall not be hurt of the second death.**

# John 5: The verse that initiated the question

28 Marvel not at this: for the hour is coming, in the which all that are in the graves shall hear his voice, 29 And shall come forth;

They that have done good,  
unto the resurrection of [life](#);  
and they that have done evil,  
unto the resurrection of [damnation](#).

(King James)

They who have done good,  
in the resurrection of [the Just](#);  
and they who have done evil,  
in the resurrection of [the Unjust](#).

(Inspired Version)

## DC 85:4-6

4a Now, verily I say unto you, that through the redemption which is made for you, is brought to pass the resurrection from the dead. And the spirit and the body is the soul of man.

4b And the resurrection from the dead is the redemption of the soul; and the redemption of the soul is through him who quickeneth all things, in whose bosom it is decreed, that the poor and the meek of the earth shall inherit it.

## DC 85:4-6

4c Therefore, it must needs be sanctified from all unrighteousness, that it may be prepared for the celestial glory; for after it hath filled the measure of its creation, it shall be crowned with glory, even with the presence of God the Father;

4d that bodies who are of the celestial kingdom may possess it for ever and ever; for, for this intent was it made and created; and for this intent are they sanctified.

## DC 85:4-6

5a And they who are not sanctified through the law which I have given unto you, even the law of Christ, must inherit another kingdom, even that of a terrestrial kingdom, or that of a telestial kingdom.

5b For he who is not able to abide the law of a celestial kingdom, can not abide a celestial glory; and he who can not abide the law of a terrestrial kingdom, can not abide a terrestrial glory; he who can not abide the law of a telestial kingdom, cannot abide a telestial glory: therefore, he is not meet for a kingdom of glory.

5c Therefore, he must abide a kingdom which is not a kingdom of glory.



## DC 85:4-6

6a And again, verily I say unto you, The earth abideth the law of a celestial kingdom, for it filleth the measure of its creation, and transgresseth not the law.

6b Wherefore, it shall be sanctified; yea, notwithstanding it shall die, it shall be quickened again, and shall abide the power by which it is quickened, and the righteous shall inherit it:

## DC 85:4-6

6c for, notwithstanding they die, they also shall rise again a spiritual body: they who are of a celestial spirit shall receive the same body, which was a natural body: even ye shall receive your bodies, and your glory shall be that glory by which your bodies are quickened.

6d Ye who are quickened by a portion of the celestial glory, shall then receive of the same, even a fullness;

6e and they who are quickened by a portion of the terrestrial glory, shall then receive of the same, even a fullness:

## DC 85:4-6

6f and also they who are quickened by a portion of the telestial glory, shall then receive of the same, even a fullness:

6g and they who remain shall also be quickened; nevertheless, they shall return again to their own place, to enjoy that which they are willing to receive, because they were not willing to enjoy that which they might have received.

## DC 85:4-6

But when it talks of 'inheritance' of these 'glories' when is the description of when the inheritance is received?

You have to read the rest of the section....

## DC 85:4-6

But when it talks of 'inheritance' of these 'glories' when is the description of when the inheritance is received?

You have to read the rest of the section....

## DC 85:25-34

25d Prepare ye, prepare ye, O inhabitants of the earth, for the judgment of our God is come: behold, and lo, the Bridegroom cometh, go ye out to meet him.

26a And immediately there shall appear a great sign in heaven, and all people shall see it together.

26b And another angel shall sound his trump, saying, That great church, the mother of abominations, that made all nations drink of the wine of the wrath of her fornication, that persecuteth the saints of God, that shed their blood:

## DC 85:25-34

26c she who sitteth upon many waters, and upon the islands of the sea; behold, she is the tares of the earth, she is bound in bundles, her bands are made strong, no man can loose them; therefore, she is ready to be burned.

26d And he shall sound his trump both long and loud, and all nations shall hear it.

## DC 85:25-34

25d Prepare ye, prepare ye, O inhabitants of the earth, for the judgment of our God is come: behold, and lo, the Bridegroom cometh, go ye out to meet him.

26a And immediately there shall appear a great sign in heaven, and all people shall see it together.

26b And another angel shall sound his trump, saying, That great church, the mother of abominations, that made all nations drink of the wine of the wrath of her fornication, that persecuteth the saints of God, that shed their blood:



## DC 85:25-34

27a And there shall be silence in heaven for the space of half an hour, and immediately after shall the curtain of heaven be unfolded, as a scroll is unfolded after it is rolled up, and the face of the Lord shall be unveiled;

27b and the saints that are upon the earth, who are alive, shall be quickened, and be caught up to meet him.

## DC 85:25-34

27c And they who have slept in their graves, shall come forth; for their graves shall be opened, and they also shall be caught up to meet him in the midst of the pillar of heaven: they are Christ's, the first fruits:

27d they who shall descend with him first, and they who are on the earth, and in their graves, who are first caught up to meet him; and all this by the voice of the sounding of the trump of the angel of God.

## DC 85:25-34

28a And after this, another angel shall sound, which is the **second trump**; and **then cometh the redemption of those who are Christ's at his coming;**

28b **who have received their part in that prison which is prepared for them,** that they might receive the gospel, **and be judged according to men in the flesh.**

## DC 85:25-34

29a And again, **another trump** shall sound, which is the third trump: and then cometh the spirits of men who are to be judged, and are found under condemnation:

29b and these are the rest of the dead, and they live not again until the thousand years are ended, neither again, until the end of the earth.

## DC 85:25-34

30 And another trump shall sound, which is the fourth trump, saying, These are found among those who are to remain until that great and last day, even the end, who shall remain filthy still.

31a And another trump shall sound, which is the fifth trump, which is the fifth angel who committeth the everlasting gospel, flying through the midst of heaven, unto all nations, kindreds, tongues, and people;

## DC 85:25-34

31b and this shall be the sound of his trump, saying to all people, both in heaven and in earth, and that are under the earth; for every ear shall hear it, and every knee shall bow, and every tongue shall confess, while they hear the sound of the trump, saying,

31c Fear God, and give glory to him who sitteth upon the throne, for ever and ever: for the hour of his judgment is come. (but what judgement is this? Keep reading..)

## DC 85:25-34

32 And again, another angel shall sound his trump, which is the sixth angel, saying, She is fallen, who made all nations drink of the wine of the wrath of her fornication: she is fallen! is fallen!

33a And again, another angel shall sound his trump, which is the seventh angel, saying: It is finished! it is finished! the Lamb of God hath overcome, and trodden the wine press alone; even the wine press of the fierceness of the wrath of Almighty God;

## DC 85:25-34

33b and then shall the angels be crowned with the glory of his might, and the saints shall be filled with his glory, and receive their inheritance and be made equal with him.

34 And then shall the first angel again sound his trump in the ears of all living, and reveal the secret acts of men, and the mighty works of God in the first thousandth year....

(judgement upon those who do and don't live in the millennium—i.e. the 1000 years)



# 1<sup>st</sup> Resurrection

(also called Resurrection of Life)  
(also called Resurrection of the Just)

# Last Resurrection

(also called Resurrection of Damnation)  
(also called Resurrection of the UnJust)

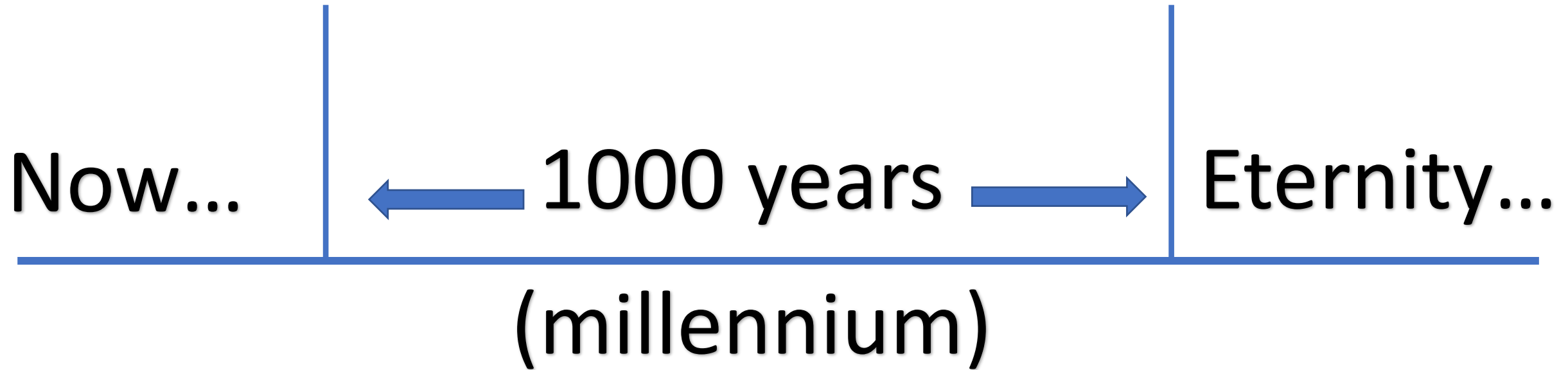

# The Willfully Rebellious

## Alma 8:97

Therefore the wicked remain as though there had been no redemption made, except it be the **loosing** of the bands of death.

# The Willfully Rebellious

## [Mosiah 1:126-127](#)

Whereof they shall be judged, every man according to his works, whether they be good or whether they be evil.

'And if they be evil, they are consigned to an awful view of their own guilt and abominations, Which doth cause them to shrink from the presence of the Lord into a state of misery and endless torment from whence they can no more return;

Therefore, they have drunk damnation to their own souls.

## 2 Nephi 6:

67 Wo unto the **uncircumcised of heart**

for a knowledge of their iniquities shall smite them at the last day;

68 Wo unto **the liar**

for he shall be thrust down to hell;

69 Wo unto the murderer who **deliberately killeth**

for he shall die;

70 Wo unto them who **commit whoredoms**

for they shall be thrust down to hell;

71 Yea, wo unto they that **worship idols**

for the devil of all devils delighteth in them;

72 And in fine, **wo unto all they that die in their sins,**

**for they shall return to God and behold His face and remain in their sins.**

*(Note: End of each phrase is a parallelism of spiritual death in varying words)*

# The Willfully Rebellious

[2 Nephi 6:72](#) And in fine,  
wo unto all they that die in their sins.  
For they shall return to God  
and **behold His face**  
and remain in their sins.

# The Thieves....

## A type for Humanity and Final Judgement

**Luke 23:34**

And when they were come to the place which is called Calvary,  
there they **crucified him and the malefactors;**  
**one on the right hand,**  
**and the other on the left.**

# The Thieves....a type for Humanity and Judgement

[Luke 23:40](#) And one of the **malefactors** who was crucified with him, railed on him, saying, If thou be the Christ, save thyself and us.

41 But the other answering, rebuked him, saying, Dost thou not fear God, seeing thou art in the same condemnation?

42 And we indeed justly; for we receive the due reward of our deeds; but this man hath done nothing amiss.

43 And he said to Jesus, Lord, remember me when thou comest into thy kingdom.

# What does Doctrine and Covenants Teach about Final Judgment? DC 28 (August 1830):

28:6a And again, verily, verily I say unto you, that when the thousand years are ended, and men again begin to deny their God, then will I spare the earth but for a little season;

28:6b and the end shall come,  
and the heaven and the earth shall be consumed and pass away,  
and there shall be a new heaven and a new earth;



# What does Doctrine and Covenants Teach about Final Judgment? DC 28 (August 1830):

28:7a But, behold, verily I say unto you, Before the earth shall pass away, Michael, mine archangel, shall sound his trump, and then shall all the dead awake, for their graves shall be opened, and they shall come forth; yea, even all;

28:7b and the righteous shall be gathered on my right hand unto eternal life; and the wicked on my left hand will I be ashamed to own before the Father;

28:7c wherefore I will say unto them, Depart from me ye cursed into everlasting fire, prepared for the Devil and his angels.

# Mormon view of Eternity

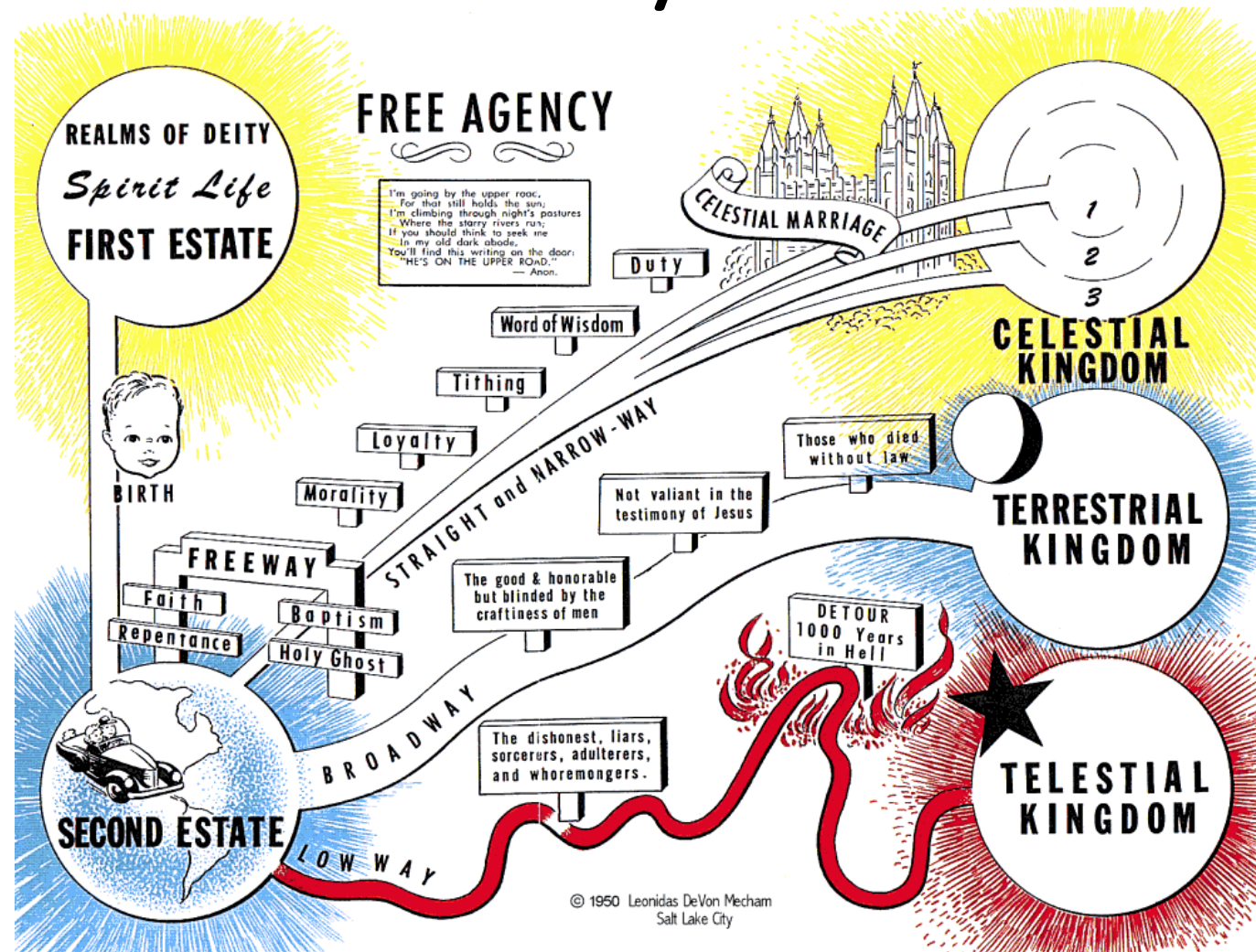

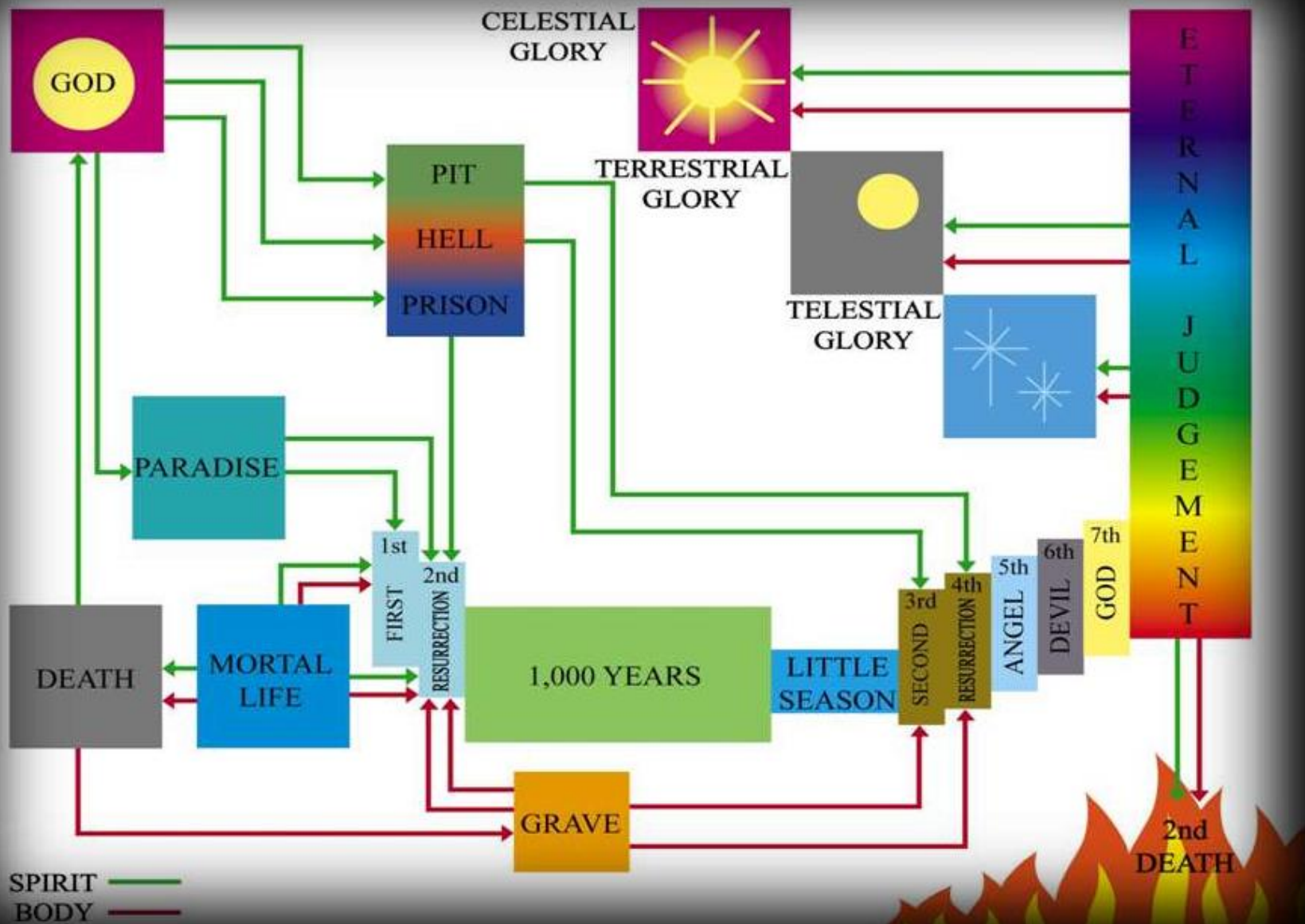

# 1 Nephi 3:125-127

125 And the mists of darkness are the temptations of the devil which blindeth the eyes and hardeneth the hearts of the children of men, And leadeth them away into broad roads, that they perish and are lost.

126 And the large and spacious building which thy father saw is vain imaginations and the pride of the children of men,

127 And a great and a terrible gulf divideth them.

Yea, even the sword of the justice of the Eternal God and Jesus Christ, which is the Lamb of God, of whom the Holy Ghost beareth record from the beginning of the world until this time, And from this time henceforth and forever."

# He Brings Us OVER the GULF

## Alma 14:101

Behold, He did not exercise His justice upon us,

But in His great mercy hath brought us over that everlasting gulf of death and misery,

even to the salvation of our souls.

# He Brings Us OVER the GULF

## Helaman 2:26

Yea, we see that whosoever will lay hold upon the word of God, which is quick and powerful, Which shall divide asunder all the cunning and the snares and the wiles of the devil,

And lead the man of Christ in a strait and narrow course across that everlasting gulf of misery which is prepared to engulf the wicked,

And land their souls, yea, their immortal souls, at the right hand of God in the kingdom of heaven, To sit down with Abraham and Isaac and with Jacob and with all our holy fathers to go no more out.

# Q.What Do Works PROVE?

## A. IF YOU WERE PENITENT

[Alma 19:105-106](#) But God ceaseth not to be God,

**And mercy claimeth the penitent,**

**And mercy cometh because of the atonement;**

And the atonement bringeth to pass the resurrection of the dead,

And the resurrection of the dead bringeth back men into the presence of God.

And thus they are restored into His presence to be judged according to their works, according to the law and justice;

For behold, **justice exerciseth all his demands,**

And also **mercy claimeth all which is her own;**

**And thus, none but the truly penitent are saved.**

# What Do Works PROVE?

## [2 Nephi 1:72](#)

Behold, He offereth Himself a sacrifice for sin to answer the ends of the law unto all those which have a broken heart and a contrite spirit,

And unto none else can the ends of the law be answered.



# To Use the language of Section 76- 'the Telestial'

But the prison house (i.e. telestial) ultimately has two types of people at any time:

- 'Bad' people whose heart eventually changes, and
- 'Bad' people whose heart never changes.

## The people in Hell whose heart changes

The Bible and DC both teach that people in the prison house who repent receive salvation at the resurrection.

# Prison House 'Releases'

I have found three instances in scripture where the prison house release (of repentant souls) is described—each at different times:

- At the Resurrection of Jesus.
- At Jesus coming in glory (resurrection of the Just)
- At the Final Judgement (resurrection of the UnJust).

**Genesis 7:63** And he heard a loud voice, and the heavens were veiled; and all the creations of God mourned, and the earth groaned; and the rocks were rent; **and the saints arose, and were crowned at the right hand of the Son of Man, with crowns of glory.**

**Genesis 7:64** **And as many of the spirits as were in prison came forth and stood on the right hand of God.** And the remainder were reserved in chains of darkness until the judgment of the great day.

# THE PRISON HOUSE—3 RECORDED 'RELEASES'

## AT JESUS DEATH AND RESURRECTION

Genesis 7:64 And as many of the spirits as were in prison came forth and stood on the right hand of God.

And the remainder were reserved in chains of darkness until the judgment of the great day.

## WHEN MILLENIUM BEGINS

85:27d they who shall descend with him first, and they who are on the earth, and in their graves, who are first caught up to meet him; and all this by the voice of the sounding of the trump of the angel of God.

85:28a And after this, another angel shall sound, which is the second trump; and then cometh the redemption of those who are Christ's at his coming;

85:28b who have received their part in that prison which is prepared for them, that they might receive the gospel, and be judged according to men in the flesh.

Revelation 20:5 But the rest of the dead lived not again until the thousand years were finished. This is the first resurrection.

## AT END OF MILLENIUM

Rev 20:13 And the sea gave up the dead which were in it; and death and hell delivered up the dead which were in them; and they were judged every man according to their works.

14 And death and hell were cast into the lake of fire. This is the second death.

15 And whosoever was not found written in the book of life was cast into the lake of fire.

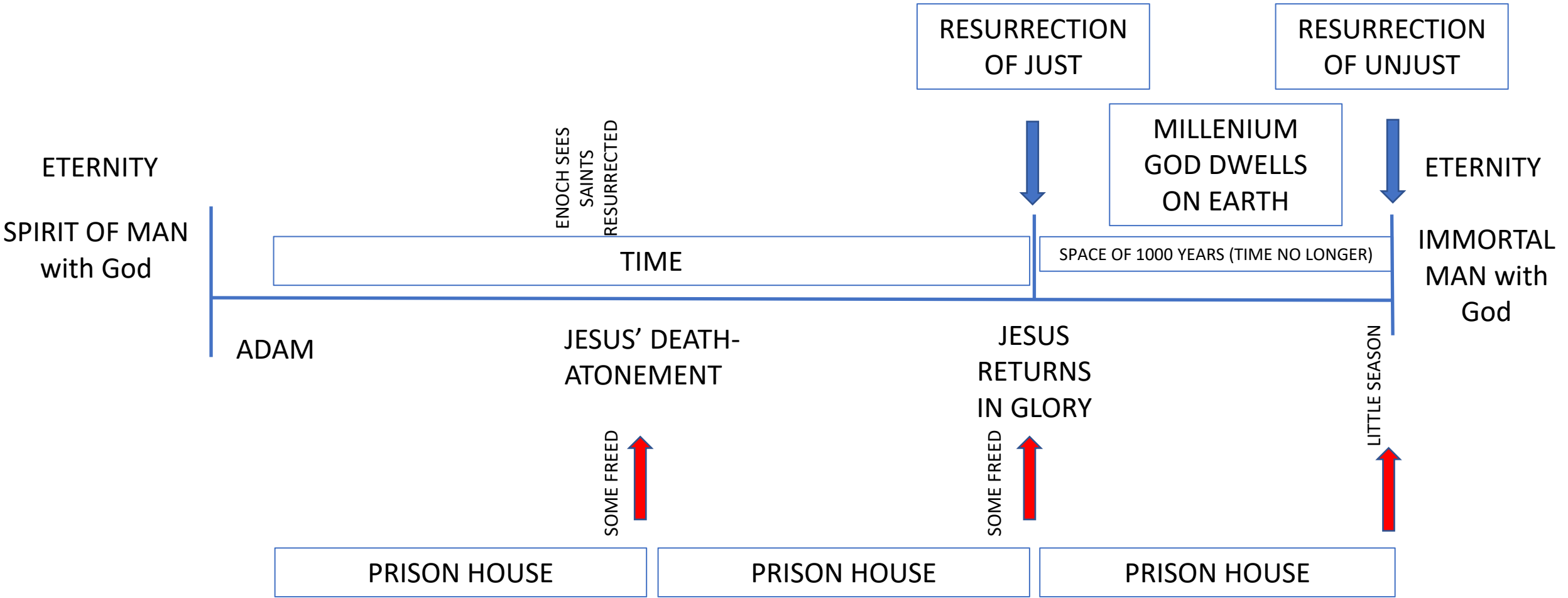

Gen 7:64 to Some God's right hand, some remain

SOME FREED, ARE DESCRIBED WITH A TERRESTRIAL RESURRECTION

[Return](#)

# Notice how DC 85 Explains itself, what/when being 'Quickened by Glory' is....

**85:6c** for, notwithstanding they die, they also shall rise again a spiritual body: they who are of a celestial spirit shall receive the same body, which was a natural body: even ye shall receive your bodies, and your glory shall be that glory by which your bodies are quickened.

**85:6d** Ye who are quickened by a portion of the celestial glory, shall then receive of the same, even a fullness;

**85:6e** and they who are quickened by a portion of the terrestrial glory, shall then receive of the same, even a fullness:

**85:6f** and also they who are quickened by a portion of the celestial glory, shall then receive of the same, even a fullness:

**85:6g** and they who remain shall also be quickened; nevertheless, they shall return again to their own place, to enjoy that which they are willing to receive, because they were not willing to enjoy that which they might have received.

27c And they who have slept in their graves, shall come forth; for their graves shall be opened, and they also shall be caught up to meet him in the midst of the pillar of heaven: they are Christ's, the first fruits:

27d they who shall descend with him first, and they who are on the earth, and in their graves, who are first caught up to meet him; and all this by the voice of the sounding of the trump of the angel of God.

# Notice how DC 85 Explains itself, what/when being 'Quickened by Glory' is....

**85:6c** for, notwithstanding they die, they also shall rise again a spiritual body: they who are of a celestial spirit shall receive the same body, which was a natural body: even ye shall receive your bodies, and your glory shall be that glory by which your bodies are quickened.

**85:6d** Ye who are quickened by a portion of the celestial glory, shall then receive of the same, even a fullness;

**85:6e** and they who are quickened by a portion of the terrestrial glory, shall then receive of the same, even a fullness:

**85:6f** and also they who are quickened by a portion of the celestial glory, shall then receive of the same, even a fullness:

**85:6g** and they who remain shall also be quickened; nevertheless, they shall return again to their own place, to enjoy that which they are willing to receive, because they were not willing to enjoy that which they might have received.

28a And after this, another angel shall sound, which is the **second trump**; and **then cometh the redemption of those who are Christ's at his coming;**

28b **who have received their part in that prison which is prepared for them,** that they might receive the gospel, and be judged according to men in the flesh.

# Notice how DC 85 Explains itself, what/when being 'Quickened by Glory' is....

**85:6c** for, notwithstanding they die, they also shall rise again a spiritual body: they who are of a celestial spirit shall receive the same body, which was a natural body: even ye shall receive your bodies, and your glory shall be that glory by which your bodies are quickened.

**85:6d** Ye who are quickened by a portion of the celestial glory, shall then receive of the same, even a fullness;

**85:6e** and they who are quickened by a portion of the terrestrial glory, shall then receive of the same, even a fullness:

**85:6f** and also they who are quickened by a portion of the celestial glory, shall then receive of the same, even a fullness:

**85:6g** and they who remain shall also be quickened; nevertheless, they shall return again to their own place, to enjoy that which they are willing to receive, because they were not willing to enjoy that which they might have received.

29a And again, **another trump** shall sound, which is the **third trump**: and then cometh the spirits of men who are to be judged, and are found under condemnation:

29b and these are the rest of the dead, and they live not again until the thousand years are ended, neither again, until the end of the earth.



## ALL DESCRIBING AS BOOK OF MORMON: BEGINNING OF MILLENIUM

Mosiah 8	DC 76	DC 85	Revelation 20
<p>41 Behold, I say unto you, that whosoever has heard the words of the prophets</p> <p>42 all those who have hearkened unto their words, and believed that the Lord would redeem his people, and have looked forward to that day for a remission of their sins;</p> <p>43 I say unto you, that these are his seed, or they are heirs of the kingdom of God:</p>	<p>76:5a ... concerning them who come forth in the resurrection of the just:</p> <p>76:5b ... who received the testimony of Jesus, and believed on his name, and were baptized ...that by keeping the commandments, they might be washed and cleansed from all their sins,</p> <p>76:5c and receive the Holy Spirit</p> <p>76:5l these are they who shall have part in the first resurrection;</p>	<p>27c And they who have slept in their graves, shall come forth; for their graves shall be opened, and they also shall be caught up to meet him in the midst of the pillar of heaven: they are Christ's, the first fruits:</p> <p>27d they who shall descend with him first, and they who are on the earth, and in their graves, who are first caught up to meet him; and all this by the voice of the sounding of the trump of the angel of God.</p>	<p>20:4 And I saw thrones, and they sat upon them, and judgment was given unto them;</p> <p>and I saw the souls of them that were beheaded for the witness of Jesus, and for the word of God, and which had not worshiped the beast, neither his image, neither had received his mark upon their foreheads, or in their hands:</p> <p>and they lived and reigned with Christ a thousand years.</p>

## **ALL DESCRIBING AS BOOK OF MORMON: FIRST RESURRECTION**

<b>Mosiah 8</b>	<b>DC 76</b>	<b>DC 85</b>	<b>Revelation 20</b>
<p>Mosiah 8: 58 And these are those who have part in the first resurrection;</p> <p>and these are they that have died before Christ came in their ignorance, not having salvation declared unto them.</p> <p>59 And thus the Lord bringeth about the restoration of these; and they have a part in the first resurrection, or have eternal life, being redeemed by the Lord.</p> <p>8:60 And little children also have eternal life.</p>	<p>76:6a And again, we saw the terrestrial world...</p> <p>76:6c Behold, these are they who died without law; and also they who are the spirits of men kept in prison, whom the Son visited, and preached the gospel unto them, that they might be judged according to men in the flesh, who received not the testimony of Jesus in the flesh, but afterwards received it;</p> <p>76:6d these are they who are honorable men of the earth, who were blinded by the craftiness of men:</p>	<p>28a And after this, another angel shall sound, which is the second trump; and then cometh the redemption of those who are Christ's at his coming;</p> <p>28b who have received their part in that prison which is prepared for them, that they might receive the gospel, and be judged according to men in the flesh.</p>	

## THOSE FOUND UNDER CONDEMNATION (ALSO CALLED PERDITION--SPEND MILLENNIUM IN PRISON HOUSE)

Mosiah 8	DC 76	DC 85	Revelation 20
<p>61 "But behold and fear and tremble before God, for ye had ought to tremble, For the Lord redeemeth none such that rebelleth against Him and dieth in their sins,</p> <p>62 Yea, even all those that have perished in their sins ever since the world began, that have willfully rebelled against God, <b>that have known the commandments of God and would not keep them</b>; <u>These are they that have no part in the first resurrection.</u></p>	<p>76:7a And again, we saw the glory of the telestial,</p> <p>76:7b <u>these are they who received not the gospel of Christ,</u> neither the testimony of Jesus; ...</p> <p>76:7d these are they who are thrust down to hell;</p> <p>76:7e <u>these are they who shall not be redeemed from the Devil, until the last resurrection,</u> until the Lord, even Christ the Lamb, shall have finished his work;</p> <p><b><u>76:7f .... for they shall be heirs of salvation.</u></b></p>	<p>29a And again, another trump shall sound, which is the third trump: and then cometh the spirits of men who are to be judged, and are found under condemnation:</p> <p>29b and <u>these are the rest of the dead, and they live not again until the thousand years are ended, neither again, until the end of the earth.</u></p> <p>30 And another trump shall sound, which is the fourth trump, saying, These are found among those who are to remain until that great and last day, even the end, who shall remain filthy still.</p>	<p>20:5 <u>But the rest of the dead lived not again until the thousand years were finished.</u> This is the first resurrection.</p>

## At End of Millennium:

### Mosiah 8

62 Yea, even all those that have perished in their sins ever since the world began, that have **wilfully rebelled** against God, that have known the commandments of God and would not keep them; These are they that have no part in the first resurrection.

### DC 76

76:4a Thus saith the Lord, concerning all those who know my power, and have been made partakers thereof, and **suffered themselves, through the power of the Devil, to be overcome, and to deny the truth, and defy my power;**

76:4b they are they who are the sons of perdition, ...

76:4c for they are vessels of wrath, doomed to suffer the wrath of God, with the Devil and his angels, in eternity,  
76:4d having denied the Holy Spirit, after having received it,

76:4e these are they who shall go away into the lake of fire and **brimstone, with the Devil and his angels, and the only ones on whom the second death shall have any power; yea, verily, the only ones who shall not be redeemed in the due time of the Lord,** after the sufferings of his wrath; for all the rest shall be brought forth by the resurrection of the dead, through the triumph and the glory of the Lamb, who was slain, who was in the bosom of the Father before the worlds were made.

### DC 85

(These are released):  
30 And another trump shall sound, which is the fourth trump, saying, These are found among those who are to remain until that great and last day, even the end, **who shall remain filthy still**

### Revelation 20

20:12 And I saw the dead, small and great, stand before God; and the books were opened; and another book was opened, which is the book of life; **and the dead were judged out of those things which were written in the books, according to their works.**

20:13 And **the sea gave up the dead which were in it; and death and hell delivered up the dead which were in them; and they were judged every man according to their works.**

20:14 And death and hell were cast into the lake of fire. This is the second death.

20:15 And whosoever was not found written in the book of life was cast into the lake of fire.

## FINAL STATE

### ALMA, NEPHI, ABINADI

#### **ALMA 16:234**

Therefore, the Spirit of the Lord hath withdrawn from you and hath no place in you, And the devil hath all power over you.

And this is the final state of the wicked.

#### **1 Nephi 4:61**

Wherefore, the final state of the souls of men is to dwell in the kingdom of God, or to be cast out because of that justice of which I have spoken;

#### **Mosiah 8:84-87**

If they be good, to the resurrection of endless life and happiness,  
and if they be evil, to the resurrection of endless damnation;  
Being delivered up to the devil, who has subjected them, which is damnation;

### DC 28

7a But, behold, verily I say unto you, Before the earth shall pass away, Michael, mine archangel, shall sound his trump, and then shall all the dead awake, for their graves shall be opened, and they shall come forth; yea, even all;

7b and the righteous shall be gathered on my right hand unto eternal life; and the wicked on my left hand will I be ashamed to own before the Father;

7c wherefore I will say unto them, Depart from me ye cursed into everlasting fire, prepared for the Devil and his angels.

### REVELATION 20

Rev 20:13 And the sea gave up the dead which were in it; and death and hell delivered up the dead which were in them; and they were judged every man according to their works.

14 And death and hell were cast into the lake of fire. This is the second death.

15 And whosoever was not found written in the book of life was cast into the lake of fire.

### MATTHEW

Matthew 25:33 And before him shall be gathered all nations; and he shall separate them one from another, as a shepherd divideth sheep from the goats; the sheep on his right hand, but the goats on his left.

# Innumerable Inhabitants

**DC 76:7t** But, behold, and lo, we saw the glory and **the inhabitants of the celestial world, that they were as innumerable as the stars** in the firmament of heaven, or as the sand upon the seashore, and heard the voice of the Lord saying...

## ...morphed into....

How many kingdoms there are has not been told to us; **they are innumerable**. (*Discourses of Brigham Young*, p.382)

**How many glories and kingdoms will there be in eternity? You will see the same variety in eternity as you see in the world.** (*Discourses of Brigham Young*, p.382)

# Innumerable Inhabitants morphed into....

From this later scripture, (D&C, Sec. 76), we learn that there are three well-defined degrees in the future state, with numerous, perhaps numberless, gradations. . . . We hold that there is a wide difference between salvation and exaltation; **that there are infinite gradations beyond the grave as there are here**, and as there were in the state preceding this. (The Story and Philosophy of "Mormonism," p.131)

**James E. Talmage**

# Innumerable Inhabitants morphed into....

We read in the Bible that there is one glory of the sun, another glory of the moon, and another glory of the stars.

In the book of Doctrine and Covenants, these glories are called telestial, terrestrial and celestial, which is the highest.

These are worlds, different departments, or mansions, in our Father's house. (*Discourses of Brigham Young*, p.382)



# Articles of Faith...written by Parley Pratt.

That every soul shall find his place in the hereafter, that he shall be judged and assigned according to what he is, is no less truly scriptural than reasonable. He shall inherit according to his capacity to receive, enjoy, and utilize. This is made sublimely plain by revelation given in 1832, in which we read: "For he who is not able to abide the law of a celestial kingdom cannot abide a celestial glory. And he who cannot abide the law of a terrestrial kingdom cannot abide a terrestrial glory. And he who cannot abide the law of a telestial kingdom cannot abide a telestial glory; therefore he is not meet for a kingdom of glory. Therefore he must abide a kingdom which is not a kingdom of glory." [D&C 88:22-24] (Articles of Faith, pp.405; italics added not for emphasis but clarity in reading)

# But Parley Pratt.....

- Married 12 wives,



# Whose Merits?

# The Merits of Christ...

## 2 Nephi 1:73

Wherefore, how great the importance to make these things known unto the inhabitants of the earth, That they may know that there is no flesh that can dwell in the presence of God, save it be through the merits and mercy and grace of the Holy Messiah,

## Alma 13:46

And since man had fallen, he could not merit anything of himself;  
But the sufferings and death of Christ atoneth for their sins through faith and repentance, etc.

# The Merits of Christ...

[Helaman 5:67](#) And if ye believe on His name, ye will repent of all your sins, that thereby ye may have remission of them through His merits.

[Moroni 6:5](#) ....relying alone upon the merits of Christ who was the author and the finisher of their faith.

[2 Nephi 13:28](#) Behold, I say unto you, Nay; For ye have not come thus far save it were by the word of Christ, with unshaken faith in Him, Relying wholly upon the merits of Him who is mighty to save.

# The Savior's Merits morphed into....

*The Celestial Glory is provided for those who merit the highest honors of heaven. In the revelation referred to, we read of them: (quotes dc 76 paragraph 5)*

*The Terrestrial Glory -- This, the next lowest degree, will be attained by many whose works do not merit the highest reward. (quotes DC 76:6)*

*The Telestial Glory -- They are thus not wholly rejected; their every merit will be respected (quotes DC 76:7)*

(James Talmage)

# Everyone Judged according to works, but what does this mean?

- Book of Mormon means that work proves brokenness, contrite, penitence. Up or down vote.
- Bible teaches this, Doctrine and Covenants teaches this.
- All the above teach salvation is based on HIS merits
  
- But oral tradition has drifted...
  - Restoration starts teaching we will be lined up and assigned a destination based on infinite classification of results, all but without God. **BASED ON OUR MERITS.** That is a serious misunderstanding of salvation.



# Mercy and Justice

# Book of Mormon teaches either Mercy or Justice....

[Alma 19:97](#) And now the **plan of mercy could not be brought about, except an atonement should be made**; Therefore, **God Himself atoneth for the sins of the world to bring about the plan of mercy to appease the demands of justice**, that God might be a perfect, just God and a merciful God also.

# Book of Mormon teaches either Mercy or Justice....

[Alma 19:104](#) But there is a law given, and a punishment affixed, and repentance granted, which repentance mercy claimeth; Otherwise, justice claimeth the creature and executeth the law, And the law inflicteth the punishment; If not so, the works of **justice** would be destroyed and God would cease to be God.

[Alma 19:106](#) And thus they are restored into His presence, to be judged according to their works, according to the law and **justice**;

For behold, justice exerciseth all his demands,  
And also mercy claimeth all which is her own;  
And thus, none but the truly penitent are saved.

# Book of Mormon teaches either Mercy or Justice....but Mormonism teaches:

The three kingdoms of widely differing glories are severally organized **on a plan of gradation**. .... Thus the innumerable degrees of merit amongst mankind are provided for in an infinity of graded glories.

There is no claim of universal forgiveness; **no unwarranted glorification of Mercy to the degrading or neglect of Justice**; no thought that a single sin of omission or of commission shall fail to leave its wound or scar. In the great future there shall be found a place for every soul, whatever his grade of spiritual intelligence may be. "In my Father's house are many mansions," (John 14:2), declared the Savior to his apostles;

James Talmage (Mormonism) :

If My Knowledge will be perfect.....then

- How could I be happy in a state without God, in a supposed 'Terrestrial Glory' if my perfect knowledge during immortality continually reminds me I will be FOREVER WITHOUT GOD.
- That would be HELL EQUAL TO FIRE AND BRIMSTONE.
- There is NO ETERNITY OF HAPPINESS AWAY FROM GOD. THESE THINGS WERE TO PUSH PEOPLE TOWARDS POLYGAMY. CELESTIAL MARRIAGE WAS TIED WITH CELESTIAL KINGDOM.
- Ridiculous to imply that we would be in a perfect state, but away from God for eternity, we are like children whose fussings can be diverted with a piece of candy??

# He Answers the Law for the Broken and Contrite

## 2 Nephi 1:72

Behold,

He offereth Himself a sacrifice for sin

to answer the ends of the law unto all those which **have  
a broken heart and a contrite spirit,**

And unto none else can the ends of the law be  
answered.

# Our Souls are Either FULLY Cleansed OR REMAIN FILTHY.

## [Alma 3:40](#)

Yea, his garments must be purified until they are cleansed from all stain through the blood of Him of whom it hath been spoken by our fathers which should come to redeem His people from their sins.

[Alma 5:25](#) Therefore, come and be baptized unto repentance, that ye may be washed from your sins, That ye may have faith on the Lamb of God which taketh away the sins of the world, which is mighty to save and to cleanse from all unrighteousness.

[Alma 19:60](#) But behold, an awful death cometh upon the wicked, For they die as to things pertaining to things of righteousness,  
For they are unclean and no unclean thing can inherit the kingdom of God;

# Our Souls are Either FULLY Cleansed OR REMAIN FILTHY.

## [1 Nephi 3:35](#)

And no **unclean thing** can dwell with God,  
wherefore, ye must be cast off forever;

## [1 Nephi 4:58](#)

But behold I say unto you, the kingdom of God is not filthy,  
And there cannot any **unclean** thing enter into the kingdom of God



# The Happy state

**Mosiah 1:88** "And moreover, I would desire that ye should consider on **the blessed and happy state of those that keep the commandments of God,**

**Mosiah 1:90** **And if they hold out faithful to the end, they are received into heaven, that thereby they may dwell with God in a state of never - ending happiness.**

# The Guilty state or Guilt Free State

[Mormon 3:29](#) And He hath brought to pass the redemption of the world, **Whereby he that is found guiltless** before Him at the judgment day hath it given unto them to dwell in the presence of God in His kingdom, To sing ceaseless praises with the choirs above unto the Father and unto the Son and unto the Holy Ghost, which is one God, **in a state of happiness which hath no end.**

# The Guilty state or Guilt Free State

## [Mosiah 1:126-127](#)

Whereof they shall be judged, every man according to his works, whether they be good or whether they be evil.

'And if they be evil, they are consigned to an awful view of their own guilt and abominations, Which doth cause them to shrink from the presence of the Lord into a state of misery and endless torment from whence they can no more return;

Therefore, they have drunk damnation to their own souls.

# The Guilty state or Guilt Free State

[2 Nephi 6:34](#) Wherefore, we shall have a perfect knowledge of all our **guilt** and our uncleanness and our nakedness;

[2 Nephi 6:92](#) That ye may not remember your awful **guilt** in perfectness and be constrained to exclaim, "Holy, holy are Thy judgments, O Lord God Almighty!

[2 Nephi 6:93](#) But I know my **guilt** - I transgressed Thy law, and my transgressions are mine; And the devil hath obtained me, that I am a prey to his awful misery."

# The Guilty state or Guilt Free State

**Mosiah 1:83** "Therefore, if that man repenteth not and remaineth and dieth an enemy to God, the demands of divine justice doth awaken his immortal soul to a lively sense of his own guilt,

If NOT repenting makes me an enemy to God, how can Repenting prevent me from being fully restored to God. 

In other words, if works determine final state of infinite levels, what good is repentance?

But whoso puts his trust in Him...

[Mosiah 11:24](#)

Nevertheless, whosoever putteth his trust in Him,  
the same shall be **lifted up** at the last day;

# 1 Corinthians 15

## Jewish New Testament compared to King James

35 But someone will ask, "In what manner are the dead raised? What sort of body do they have?"

36 Stupid! When you sow a seed, it doesn't come alive unless it first dies.

37 Also, what you sow is not the body that will be, but a bare seed of, say, wheat or something else;

35 But some man will say, How are the dead raised up? and with what body do they come?

36 Thou fool, that which thou sowest is not quickened, except it die:

37 And that which thou sowest, thou sowest not that body that shall be, but bare grain, it may chance of wheat, or of some other grain:

(Jewish New Testament )

<https://www.bible.com/bible/1275/1CO.15.CJB>

(King James Version)

[Return](#)

# 1 Corinthians 15

## Jewish New Testament compared to King James

38 but God gives it the body he intended for it; and to each kind of seed he gives its own body.

39 Not all living matter is the same living matter; on the contrary, there is one kind for human beings, another kind of living matter for animals, another for birds and another for fish.

(Jewish New Testament)

<https://www.bible.com/bible/1275/1CO.15.CJB>

38 But God giveth it a body as it hath pleased him, and to every seed his own body.

39 All flesh is not the same flesh: but there is one kind of flesh of men, another flesh of beasts, another of fishes, and another of birds.

(King James Version)

[Return](#)



# 1 Corinthians 15

## Jewish New Testament compared to King James

40 Further,  
there are heavenly bodies  
and earthly bodies;  
**but the beauty of heavenly bodies is one thing,**  
while the **beauty of earthly** bodies is something else.

41 The **sun has one kind of beauty,**  
**the moon another,**  
**the stars yet another;**  
**indeed, each star has its own individual kind of beauty.**

(Jewish New Testament)

<https://www.bible.com/bible/1275/1CO.15.CJB>

40 There are also celestial bodies,  
and bodies terrestrial:

but the glory of the celestial is one, and  
the glory of the terrestrial is another.

41 here is one glory of the sun,  
and another glory of the moon,  
and another glory of the stars:  
for one star differeth from another star  
in glory.

(King James Version)

Note Hebrew  
Parallelisms  
Throughout  
1 Corinthians 15

[Return](#)

# 1 Corinthians 15

## Jewish New Testament compared to King James

42 So it is with the resurrection of the dead.

When the body is “**sown**,” it decays;

when it is **raised**, it cannot decay.

43 When sown, it is **without dignity**;

when raised, it will **be beautiful**.

When sown, it is **weak**;

when raised, it will be **strong**.

44 When **sown**,

it is an **ordinary human body**;

when raised,

it will be a body **controlled by the Spirit**.

If there is an **ordinary human body**,

there is also a **body controlled by the Spirit**.

(Jewish New Testament)

<https://www.bible.com/bible/1275/1CO.15.CJB>

42 So also is the resurrection of the dead.

It is sown in corruption; it is raised in incorruption:

43 It is sown in dishonour; it is raised in glory: it is sown in weakness; it is raised in power:

44 It is sown a natural body; it is raised a spiritual body. There is a natural body, and there is a spiritual body.

(King James Version)

Note Hebrew  
Parallelisms  
Throughout  
1 Corinthians 15

[Return](#)

# DC 76

Intro: SECTION 76 On their return from the Amherst (Ohio) conference to Hiram, Ohio (D. and C. 75), Joseph Smith resumed translation of the Scriptures with Sidney Rigdon as his scribe.

On February 16, 1832, while they were thus engaged, they came to John 5:29.

While meditating on the rendition they were given by the spirit of revelation, they shared a vision which they reported in the words of this section.

# DC 76

1a Hear, O ye heavens, and give ear, O earth, and rejoice ye inhabitants thereof, for the Lord is God, and beside him there is no Savior;

1b great is his wisdom; marvelous are his ways; and the extent of his doings, none can find out;

1c his purposes fail not, neither are there any who can stay his hand; from eternity to eternity he is the same, and his years never fail.

# DC 76

2a For thus saith the Lord, I, the Lord, am merciful and gracious unto those who fear me, and delight to honor those who serve me in righteousness and in truth unto the end;

2b great shall be their reward, and eternal shall be their glory; and to them will I reveal all mysteries; yea, all the hidden mysteries of my kingdom from days of old; and for ages to come will I make known unto them the good pleasure of my will concerning all things pertaining to my kingdom;

# DC 76

2c yea, even the wonders of eternity shall they know, and things to come will I show them, even the things of many generations; their wisdom shall be great, and their understanding reach to heaven; and before them the wisdom of the wise shall perish, and the understanding of the prudent shall come to naught;

# DC 76

2d for by my Spirit will I enlighten them, and by my power will I make known unto them the secrets of my will; yea, even those things which eye has not seen, nor ear heard, nor yet entered into the heart of man.

3a We, Joseph Smith, Jr., and Sidney Rigdon, being in the Spirit on the sixteenth of February, in the year of our Lord one thousand eight hundred and thirty-two, by the power of the Spirit our eyes were opened, and our understandings were enlightened, so as to see and understand the things of God;

# DC 76

3b even those things which were from the beginning before the world was, which were ordained of the Father, through his only begotten Son, who was in the bosom of the Father, even from the beginning, of whom we bear record, and the record which we bear is the fullness of the gospel of Jesus Christ, who is the Son, whom we saw and with whom we conversed in the heavenly vision;



# DC 76

3c for while we were doing the work of translation, which the Lord had appointed unto us, we came to the twenty-ninth verse of the fifth chapter of John, which was given unto us as follows:

3d speaking of the resurrection of the dead, concerning those who shall hear the voice of the Son of man, and shall come forth; they who have done good in the resurrection of the just, and they who have done evil in the resurrection of the unjust.

# DC 76

3e Now this caused us to marvel, for it was given unto us of the Spirit, and while we meditated upon these things, the Lord touched the eyes of our understandings, and they were opened, and the glory of the Lord shone round about;

3f and we beheld the glory of the Son, on the right hand of the Father, and received of his fullness; and saw the holy angels, and they who are sanctified before his throne, worshiping God and the Lamb, who worship him for ever and ever.

# DC 76

3g And, now, after the many testimonies which have been given of him, this is the testimony, last of all, which we give of him, that he lives; for we saw him, even on the right hand of God;

3h and we heard the voice bearing record that he is the Only Begotten of the Father; that by him, and through him, and of him, the worlds are and were created; and the inhabitants thereof are begotten sons and daughters unto God.

# DC 76

3i And this we saw also, and bear record, that an angel of God, who was in authority in the presence of God, who rebelled against the only begotten Son; whom the Father loved, and who was in the bosom of the Father;

3j and was thrust down from the presence of God and the Son, and was called Perdition; for the heavens wept over him; he was Lucifer, a son of the morning. And we beheld, and lo, he is fallen! is fallen! even a son of the morning.

## DC 76

3k And while we were yet in the Spirit, the Lord commanded us that we should write the vision; for we beheld Satan, that old serpent, even the Devil, who rebelled against God, and sought to take the kingdom of our God and his Christ;

3l wherefore he maketh war with the saints of God, and encompasses them round about.

# DC 76

3m And we saw a vision of the sufferings of those with whom he made war and overcame, for thus came the voice of the Lord unto us.

# DC 76

4a Thus saith the Lord, concerning all those who know my power, and have been made partakers thereof, and suffered themselves, through the power of the Devil, to be overcome, and to deny the truth, and defy my power;

4b they are they who are the sons of perdition, of whom I say it had been better for them never to have been born;

# DC 76

4c for they are vessels of wrath,  
doomed to suffer the wrath of God,  
with the Devil and his angels, in  
eternity, concerning whom I have said  
there is no forgiveness in this world nor  
in the world to come;

4d having denied the Holy Spirit, after  
having received it, and having denied  
the only begotten Son of the Father;  
having crucified him unto themselves,  
and put him to an open shame:



# DC 76

4e these are they who shall go away into the lake of fire and brimstone, with the Devil and his angels, and the only ones on whom the second death shall have any power; yea, verily, the only ones who shall not be redeemed in the due time of the Lord, after the sufferings of his wrath;

4f for all the rest shall be brought forth by the resurrection of the dead, through the triumph and the glory of the Lamb, who was slain, who was in the bosom of the Father before the worlds were made.

# DC 76

4g And this is the gospel, the glad tidings which the voice out of the heavens bore record unto us, that he came into the world, even Jesus to be crucified for the world, and to bear the sins of the world, and to sanctify the world, and to cleanse it from all unrighteousness;

4h that through him all might be saved, whom the Father had put into his power, and made by him; who glorifies the Father, and saves all the works of his hands, except those sons of perdition, who deny the Son after the Father has revealed him;

# DC 76

4i wherefore he saves all except them; they shall go away into everlasting punishment, which is endless punishment, which is eternal punishment, to reign with the Devil and his angels in eternity, where their worm dieth not and the fire is not quenched, which is their torment, and the end thereof, neither the place thereof, nor their torment, no man knows;

4j neither was it revealed, neither is, neither will be revealed unto man, except to them who are made partakers thereof:

# DC 76

4k nevertheless, I, the Lord, show it by vision unto many; but straightway shut it up again; wherefore the end, the width, the height, the depth, and the misery thereof, they understand not, neither any man except them who are ordained unto this condemnation.

4l And we heard the voice saying, Write the vision, for lo, this is the end of the vision of the sufferings of the ungodly!

# DC 76

5a And again, we bear record for we saw and heard, and this is the testimony of the gospel of Christ, concerning them who come forth in the resurrection of the just:

# DC 76

5b They are they who received the testimony of Jesus, and believed on his name, and were baptized after the manner of his burial, being buried in the water in his name, and this according to the commandment which he has given, that by keeping the commandments, they might be washed and cleansed from all their sins,

# DC 76

5c and receive the Holy Spirit by the laying on of the hands of him who is ordained and sealed unto this power;

5d and who overcome by faith, and are sealed by that Holy Spirit of promise, which the Father sheds forth upon all those who are just and true;

5e they are they who are the church of the Firstborn;

# DC 76

5f they are they into whose hands the Father has given all things:

5g they are they who are priests and kings, who have received of his fullness, and of his glory, and are priests of the Most High after the order of Melchisedec, which was after the order of Enoch, which was after the order of the only begotten Son:



## DC 76

5h wherefore, as it is written, they are gods, even the sons of God; wherefore all things are theirs, whether life or death, or things present, or things to come, all are theirs, and they are Christ's, and Christ is God's; and they shall overcome all things;

5i wherefore let no man glory in man, but rather let him glory in God, who shall subdue all enemies under his feet;

# DC 76

5j these shall dwell in the presence of God and his Christ for ever and ever:

5k these are they whom he shall bring with him, when he shall come in the clouds of heaven, to reign on the earth over his people;

5l these are they who shall have part in the first resurrection;

# DC 76

5m these are they who shall come forth in the resurrection of the just;

5n these are they who are come unto Mount Zion, and unto the city of the living God, the heavenly place, the holiest of all;

5o these are they who have come to an innumerable company of angels; to the general assembly and church of Enoch, and of the Firstborn;

# DC 76

5p these are they whose names are written in heaven, where God and Christ are the judge of all;

5q these are they who are just men made perfect through Jesus the mediator of the new covenant, who wrought out this perfect atonement through the shedding of his own blood;

# DC 76

5r these are they whose bodies are celestial, whose glory is that of the sun, even the glory of God the highest of all; whose glory the sun of the firmament is written of as being typical.

# DC 76

6a And again, we saw the terrestrial world, and, behold, and lo;

6b these are they who are of the terrestrial, whose glory differs from that of the church of the Firstborn, who have received the fullness of the Father, even as that of the moon differs from the sun of the firmament.

# DC 76

6c Behold, these are they who died without law; and also they who are the spirits of men kept in prison, whom the Son visited, and preached the gospel unto them, that they might be judged according to men in the flesh, who received not the testimony of Jesus in the flesh, but afterwards received it;

# DC 76

6d these are they who are honorable men of the earth, who were blinded by the craftiness of men:

6e these are they who receive of his glory, but not of his fullness;



# DC 76

6f these are they who receive of the presence of the Son, but not of the fullness of the Father; wherefore they are bodies terrestrial, and not bodies celestial, and differ in glory as the moon differs from the sun;

6g these are they who are not valiant in the testimony of Jesus; wherefore they obtained not the crown over the kingdom of our God.

# DC 76

6h And now this is the end of the vision which we saw of the terrestrial, that the Lord commanded us to write while we were yet in the Spirit.

# DC 76

7a And again, we saw the glory of the telestial, which glory is that of the lesser, even as the glory of the stars differs from that of the glory of the moon in the firmament;

7b these are they who received not the gospel of Christ, neither the testimony of Jesus;

7c these are they who deny not the Holy Spirit;

7d these are they who are thrust down to hell;

# DC 76

7a And again, we saw the glory of the telestial, which glory is that of the lesser, even as the glory of the stars differs from that of the glory of the moon in the firmament;

7b these are they who received not the gospel of Christ, neither the testimony of Jesus;

7c these are they who deny not the Holy Spirit;

7d these are they who are thrust down to hell;

# DC 76

7e these are they who shall not be redeemed from the Devil, until the last resurrection, until the Lord, even Christ the Lamb, shall have finished his work;

# DC 76

7e these are they who shall not be redeemed from the Devil, until the last resurrection, until the Lord, even Christ the Lamb, shall have finished his work;

## DC 76

7f these are they who receive not of his fullness in the eternal world, but of the Holy Spirit through the ministration of the terrestrial; and the terrestrial through the ministration of the celestial: and also the telestial receive it of the administering of angels, who are appointed to minister for them, or who are appointed to be ministering spirits for them, for they shall be heirs of salvation.

# DC 76

7g And thus we saw in the heavenly vision, the glory of the telestial which surpasses all understanding; and no man knows it except him to whom God has revealed it.

7h And thus we saw the glory of the terrestrial, which excels in all things the glory of the telestial, even in glory, and in power, and in might, and in dominion.



# DC 76

7i And thus we saw the glory of the celestial, which excels in all things; where God, even the Father, reigns upon his throne for ever and ever, before whose throne all things bow in humble reverence and give him glory for ever and ever.

# DC 76

7j They who dwell in his presence are the church of the First-born; and they see as they are seen, and know as they are known, having received of his fullness and of his grace; and he makes them equal in power, and in might, and in dominion.

7k And the glory of the celestial is one, even as the glory of the sun is one. And the glory of the terrestrial is one, even as the glory of the moon is one.

# DC 76

71 And the glory of the telestial is one, even as the glory of the stars is one, for as one star differs from another star in glory, even so differs one from another in glory in the telestial world; for these are they who are of Paul, and of Apollos, and of Cephas;

# DC 76

7m these are they who say they are some of one and some of another, some of Christ, and some of John, and some of Moses, and some of Elias; and some of Esais, and some of Isaiah, and some of Enoch, but received not the gospel, neither the testimony of Jesus, neither the prophets; neither the everlasting covenant;

# DC 76

7n last of all, these all are they who will not be gathered with the saints, to be caught up unto the church of the Firstborn, and received into the cloud;

7o these are they who are liars, and sorcerers, and adulterers, and whoremongers, and whosoever loves and makes a lie;

# DC 76

7p these are they who suffer the wrath of God on the earth;

7q these are they who suffer the vengeance of eternal fire;

7r these are they who are cast down to hell and suffer the wrath of Almighty God until the fullness of times, when Christ shall have subdued all enemies under his feet, and shall have perfected his work, when he shall deliver up the kingdom and present it unto the Father spotless, saying:

# DC 76

7s I have overcome and have trodden the wine press alone, even the wine press of the fierceness of the wrath of Almighty God; then shall he be crowned with the crown of his glory, to sit on the throne of his power to reign for ever and ever.

7t But, behold, and lo, we saw the glory and the inhabitants of the telestial world, that they were as innumerable as the stars in the firmament of heaven, or as the sand upon the seashore, and heard the voice of the Lord saying:

# DC 76

7u These all shall bow the knee, and every tongue shall confess to him who sits upon the throne for ever and ever;

7v for they shall be judged according to their works; and every man shall receive according to his own works, and his own dominion, in the mansions which are prepared, and they shall be servants of the Most High, but where God and Christ dwell they cannot come, worlds without end.



# DC 76

7w This is the end of the vision which we saw, which we were commanded to write while we were yet in the Spirit.

# Zechariah 7

9 Thus speaketh the Lord of hosts, saying, Execute true judgment, and shew mercy and compassions every man to his brother;

10 And oppress not the widow, nor the fatherless, the stranger, nor the poor; and let none of you imagine evil against his brother in your heart.

11 But they refused to hearken, and pulled away the shoulder, and stopped their ears, that they should not hear.

I am here to bring the peace of God's word.

I am here to put down contention, God's word puts down contention.

A time in Nephites when the sign was given of his birth—many start preaching no longer required to keep law of Moses. They were corrected in their error. How, by a specific reading of the word.

Not here to change, the Holy Spirit is what changes, truth is what changes.

Never fear the word of God read in context.

Also, keep emotions in check—remember backpack story.

The problem is in times past some read partial words, we have exacto knife doctrine as well we just don't know it.

Spent 30 weeks teaching the covenants because our people isolated one scripture from Genesis and assumed it tells the whole story of Zion, largely ignoring many others, or if read, can't see how they fit in.

To understand, you can't start there.

To understand salvation, eternity, you can't start with DC76, but often that is 'the news' we think the restored church was commissioned to share, shared however by a partial understanding.

- Infinite salvation conjures up a God who is spiritually impotent to save.
- Those he can not save are those who rebel.
- Sin can't be removed
- The message is if your heart is broken, all sin can be removed. We teach nothing of this. The blood that cleanses, relying wholly on his merits.
- There is not a handwidth between the worst of the best and best of the worst, there is a wide gulf. The difference is OBVIOUS, a child could discern the difference.
- As if it will take a complex formula incorporating your every work, your every action, to calculate the exact place in infinity you will be placed, likely away from God.
- Instead there is a simple formula that says do the works of your life suggest your heart changed, were you happy to serve or not despite your trials. The difference between you and the wicked is obvious. It is as obvious as the attitude of the two thieves on the cross. THAT IS THE SPIRITUAL TYPE FOR SALVATION. YOU COME TO CHRIST IN HUMILITY OR YOU DO NOT.

- Our problem historically is that eternity, the time after final judgement, is taught that there are infinite levels of salvation.
- Where did that come from? Why?
  
- The Book of Mormon does not teach that
- But will find the Doctrine and Covenants does not teach it either.
- DC76 On February 16, 1832
- DC85 December 27, 1832

# Merits

Problem with infinite places of eternity is Merits

My Merits or His Merits

Wholly on Jesus Merits—the WHOLE POINT IS THAT SIN HAS TO BE REMOVED. NOTHING I COULD DO COULD REMOVE MY SIN.

IF MY SIN IS REMOVED, HIS GRACE IS APPLIED BECAUSE OF HIS MERITS.

MY SIN IS REMOVED WHEN MY HEART CHANGES, I COME TO HIM BROKEN AND CONTRITE, THEN HIS GRACE IS SUFFICIENT.

THEN I AM FULLY RESTORED TO HIM.

# INFINITE LEVELS OF SALVATION

- WAS A CONSTRUCT OF MEN WHOSE HEARTS HAD ULTERIOR MOTIVES
- CAME OUT OF AN ERA WHEN MENS MINDS WERE CLOUDED WITH ADULTERY.
- CAME BY NOT READING THE FIRST SCRIPTURES FIRST.
- IF YOU WANT TO UNDERSTAND THE NEW TESTAMENT, START BY READING THE OLD TESTAMENT.
- ONE PROBLEM, IF YOU BEGIN YOUR JOURNEY TO UNDERSTAND SALVATION AND BEGIN WITH DC 76, AND THEN BECAUSE ITS CONFUSING THEN HEAR EXPLANATION FROM SOMEONE CLAIMING TO UNDERSTAND IT, YOUR UNDERSTANDING MAY BECOME NO DIFFERENT THAN SOME WHO SIMPLY CLAIM ROMANS 10:9—CONFESS WITH YOUR MOUTH AND YOU WILL BE SAVED.

# Scriptures Describing Resurrection--

The Doctrine and Covenants teaches what the Book of Mormon teaches, we've just had it explained incorrectly and never re-examined the word.



# The point isn't...

- So much that our understanding is perfect. It doesn't change our outcome for eternity if we come in at the gate, walk in the way.
- What it DOES change, is how we represent our God to each other and the world.
- If infinite levels of salvation, then it is about my merits
- If salvation is being restored to his presence, then it is about HIS merits.
- If infinite levels of salvation is true, then why do I need a savior.
- One says my work determines where I reside in eternity most without him. Defines salvation as just not in hell.
- Book of Mormon teaches my sin was the problem from the beginning, my sin is what separates me from him now, my sin is what needs to be removed otherwise I am separated from him for eternity.
- My works do not fit into a complex equation that sends me to an infinite number of places, (the innumerable was the inhabitants of the telestial, not the number of places). But a simple determination that my works prove if my heart was changed.
- Then GRACE CAN BE APPLIED. MY SIN REMOVED, I AM FULLY RESTORED TO HIM. The problem started with sin, the problem ends with sin. WE HAVE A BEAUTIFUL MESSAGE WE HAVE NOT BEEN SHARING. FOR A NOTION THAT DERIVED FROM DUBIOS MEN WITH ULTERIOR MOTIVES.
- His passion is our immortality WITH HIM.
- This is not the willy Wonka plot twist when Charlie thinks he won the prize to be read a list of technicalities.
- How is it that Jews after 2000 years alienated from him, are then said I will come after you with a passion, but then send you off for eternity where you will never see me again?
- The promises to the covenant people, the promises of the book of Mormon are all for naught if salvation does not mean returning to God. Come buy milk and honey without money and without price.
- Salvation is ONLY defined as returning to God.

# These are the Conditions—True in Both Accounts

- Sin must be removed
- Resurrection
- The Millennium
- The Final Judgement—left hand/right hand
  - The Good have sin removed. Return to God.
- The Willfully Rebellious

# Historical Talking Points....

- Our people historically confused a specific description of the resurrection of the just with final judgment
- Became repeated and expanded upon.

# Keep in Mind

No Single Verse of Scripture describes all the judgments , attributes, conditions in one verse or section.

Not difficult to compile, but have to know if it is describing

- 1<sup>st</sup> Resurrection
- Last Resurrection
- Vs. Eternity.

This is where we failed to distinguish scripture.

(No different than covenants and Zion, or Romans 10:9)

Jesus sign of birth or death—incorrect notion, had to be corrected by scripture.

Also, don't know the hearts of some who propagated these ideas initially...

# Can't read a verse out of context

- For instance, can't read first part of DC 85 without the last part.

# Alma 19—'Plain Talk' about Resurrection

62 And now my son,

I have somewhat to say concerning **the restoration** of which has been spoken,

For behold,

**some have wrested the scriptures**

and have **gone far astray**

because of this thing;

# Alma 19—'Plain Talk' about Resurrection

63 And I perceive that thy mind hath  
been worried also concerning this thing,

But behold, I will explain it unto thee.

# Alma 19—'Plain Talk' about Resurrection

64 I say unto thee my son,

that the plan of restoration is requisite  
with the justice of God.

For it is requisite that all things should be  
restored to their proper order;



# Alma 19—'Plain Talk' about Resurrection

65 Behold it is requisite and just,  
according to the power and resurrection  
of Christ,

that the soul of man should be restored  
to its body,

And that every part of the body should  
be restored to itself.

# Alma 19—'Plain Talk' about Resurrection

66 And it is  
requisite with the justice of God  
  
that men should be  
  
judged according to their works.

# Alma 19—'Plain Talk' about Resurrection

And if their works were good in this life  
and the desires of their hearts were good,

that they should also at the last day  
be restored unto that which is good;

67 And if his works are evil,  
they shall be restored unto him for evil.

# Alma 19—'Plain Talk' about Resurrection

Therefore, all things shall be  
restored to its proper order  
everything to its natural frame.

Mortality raised to immortality,  
corruption to incorruption.

Raised to endless happiness  
to inherit the kingdom of God.

Or, to endless misery,  
to inherit the kingdom of the devil;

# Alma 19—'Plain Talk' about Resurrection

68 The one on one hand;  
the other, on the other.  
The one raised to happiness  
    according to his desires of happiness,  
or good,  
    according to his desires of good;  
And the other to evil,  
    according to his desires of evil.

For as he has desired to do evil all the day long,  
even so shall he have his reward of evil when  
the night cometh."

# Alma 19—'Plain Talk' about Resurrection

69 And so it is on the other hand.

If he hath repented of his sins  
and desired righteousness until the end of  
his days,

even so shall he be rewarded unto  
righteousness.

70 These are they that are redeemed of the  
Lord.

# Alma 19—'Plain Talk' about Resurrection

Yea,  
these are they that are taken out,  
that are delivered from that endless night  
of darkness.

And thus they stand or fall.

For behold, they are their own judges,  
whether to do good or do evil.

# Alma 19—'Plain Talk' about Resurrection

71 Now the decrees of God are unalterable;

Therefore, the way is prepared that whosoever will may walk therein and be saved.



# Alma 19—'Plain Talk' about Resurrection

62 And now my son,

I have somewhat to say concerning **the restoration** of which has been spoken,

For behold,

**some have wrested the scriptures**

and have **gone far astray**

because of this thing;

# Alma 19—'Plain Talk' about Resurrection

63 And I perceive that thy mind hath  
been worried also concerning this thing,

But behold, I will explain it unto thee.

# Alma 19—'Plain Talk' about Resurrection

64 I say unto thee my son,

that the plan of restoration is  
**requisite with the justice of**  
**God.**

**For it is requisite** that

**all things should be restored**

to their proper order;

65 Behold

**it is requisite and just,**

according to the power and  
resurrection of Christ,

that the soul of man should be  
restored to its body,

And that every part of the  
body should be restored to  
itself.

66 And it is

**requisite with the justice of God**

that men should be

judged according to their works.

# Alma 19—What is Requisite?

**#1** that the plan of restoration is requisite with the justice of God.

For it is requisite that all things should be restored to their proper order;

**#2** 65 Behold it is requisite and just, according to the power and resurrection of Christ, that the soul of man should be restored to its body,

And that every part of the body should be restored to itself.

**#3** 66 And it is requisite with the justice of God that men should be judged according to their works.

# Alma 19—What is Requisite?

**#1**

the plan of restoration

**#2**

that the soul of man should be restored to its body,

**#3**

that men should be judged according to their works.

# Alma 19—'Plain Talk' about Resurrection

And if their works were good in this life  
and the desires of their hearts were good,

that they should also at the last day  
be restored unto that which is good;

67 And if his works are evil,  
they shall be restored unto him for evil.

works were good

desires good,

restored to good;

works evil,

restored unto evil.

# Alma 19—'Plain Talk' about Resurrection

Therefore, all things shall be restored to its proper order everything to its natural frame.

**Mortality** raised to **immortality**,  
**corruption** to **incorruption**.

Raised to endless happiness  
to inherit the kingdom of God.

Or, to endless misery,  
to inherit the kingdom of the devil;

All Things

Proper Frame/Natural Frame.

Mortality/Immortality

Corruption/Incorruption

Endless Happiness/ Endless Misery

Inherit Kingdom of God/

Inherit Kingdom of Devil

# Alma 19—'Plain Talk' about Resurrection

68 The one on one hand;  
the other, on the other.

The one raised to happiness  
according to his desires of happiness,  
or good,  
according to his desires of good;  
And the other to evil,  
according to his desires of evil.

For as he has desired to do evil  
all the day long,  
even so shall he have his reward of evil  
when the night cometh."

One Hand/Other Hand

Raised to Happiness/Evil

Desires of Good/Evil

Endless Happiness/ Endless Misery

This life/Eternity

The Day/The Night



# Alma 19—'Plain Talk' about Resurrection

69 And so it is on the other hand.

If he hath repented of his sins  
and desired righteousness until the end of his days,

even so shall he be rewarded unto righteousness.

70 These are they that are redeemed of the Lord.

One Hand/Other Hand

Repent (i.e. COME IN AT THE GATE,  
WALK IN THE WAY)

Desire Righteousness

Reward for Righteousness

THIS IS REDEMPTION.

# Alma 19—'Plain Talk' about Resurrection

Yea,  
these are they that are taken out,  
that are delivered from that endless  
night of darkness.

And thus they stand or fall.

For behold, they are their own  
judges,  
whether to do good or do evil.

These are 'TAKEN OUT'

DELIVERED

All his Days/Endless Night of  
Darkness

We Stand or Fall based on our own  
decisions—whether we judge to do  
GOOD OR EVIL.

THIS IS REDEMPTION.

# Alma 19—'Plain Talk' about Resurrection

71 Now the decrees of God are unalterable;

**Therefore, the way is prepared**  
**that whosoever will**  
**may walk therein and be saved.**

This can not change.

This will not be changed.

The way is prepared for ALL who will choose to walk therein.

Priesthood named.....Melchizedek???

After Who?

Why?

Also applies to Church 'of the Firstborn.'

# Kingdom of Heaven vs Kingdom of God?

IS THE SAME THING.

Of Heaven vs of God---Not two different places, concepts, or even a Place at all.

# Heaven

By [Jeff A. Benner](#)

שמים shamayim

The Hebrew word for “heaven” is שמים shamayim. There is some debate over the origins and meanings of this word but, there are a few common theories.

1. Derived from the unused root שמה shamah possibly meaning lofty. The plural form of this word would be שמים shamayim.
2. Derived from the root שם shamam meaning Desolate, in the sense of a dry wind blowing over the land drying it out. The plural form of this word would also be שמים shamayim.
3. The word shamayim may be the Hebrew word מים mayim, meaning water, and the prefix ש sh meaning like. Combined, the word שמים shamayim would mean “like water.”

# Heaven

By Jeff A. Benner

שמים

shamayim

Aside from the debate over the origins of the word it is clear that the word is commonly used in the Biblical text for “sky.” It is frequently used in conjunction with the word ארץ *erets*, meaning land (see Gen 1:1, 2:1 and 14:19), representing the whole of creation and the domain of God.

**In the New Testament this word was used as a Euphemism** (one word used in place of another) for God.

This can be seen in some of the parables where the book of Luke (written for Gentiles) **uses the phrase “Kingdom of God”** whereas Matthew (written to Jews) **uses “Kingdom of Heaven.” In this context, heaven is meant to represent God, not a place.**

# Book of Mormon Teaches..

I have 'spoken Plain...'

[2 Nephi 11:37](#) And now my brethren, I have spoken plain that ye cannot err;

[Alma 3:72](#) For behold, I have spoken unto you plain that ye cannot err, or have spoken according to the commandments of God,

[Alma 10:21](#) and they are made known unto us in plain terms that we may understand, that we cannot err, ....



